

Model Name	Switch-M16eG	Product Specification	401-28160K-SG-SP03
Model No.	PN28160K-SG		Page 1 of 10
<p>1. Summary</p> <p>Switch-M16eG is an all Giga bit Ethernet Switch with management function having 14 ports of 10/100/1000BASE-T and two pairs of 10/100/1000BASE-T port and SFP extension slot, one of which is selectable.</p> <p>2. Feature</p> <ol style="list-style-type: none"> (1) Has wire-speed Layer 2 switching function. (2) Ports 1 to 14 are 10/100/1000BASE-T ports corresponding to auto-negotiation. Also their speed and communication mode can be switched by configuration. Ports 15 and 16 can be used as a 10/100/1000BASE-T port corresponding to auto-negotiation or an SFP extension slot exclusively. Also their speed and communication mode can be switched by configuration. (3) All twisted pair ports support straight/cross cable auto sensing function. Simply connect devices with straight cables, whether it is a terminal or a network device. (This function does not work if the port communication configuration is set at Fixed or Link Aggregation. Ports 1 to 14 are set at MDI-X. (default) (4) Has a loop detection function, which notifies when a loop occurs with the corresponding port LED and automatically shuts down the looped port. (5) Has a loop detection history function, which notifies when a loop occurs with the corresponding LED and enables a network administrator to identify the looped port after the loop is removed. (6) Fan less design solves noise problem or fan failure. (7) Due to the ECO mode LED function, Port LED lamps (left) can be turned off to reduce power consumption. (8) The IEEE802.1p compatible QoS function is supported. (9) Has an internet mansion function, which ensures security between each port. (10) Due to the loop detection/shutoff function, a port where loop has occurred can be automatically shut off to prevent loop failures. When a port is shut off and recovered automatically, SNMP trap can be sent to notify the incident to the administrator. Moreover, the port with a loop can be identified by loop notification on the LEDs on the main unit and referring the history of loop on the setting screen. (11) Has a port grouping function, which groups ports that are allowed to communicate with one another to limit communications between different groups. (12) Equipped with energy efficient Ethernet (EEE) conforming to IEEE802.3az (LPI). When there is no data transmission at link up, the energy-saving state automatically starts so that power consumption can be reduced on each port. (13) Using Embedded power-saving mode, connection status is automatically detected and power consumption is minimized. (14) Supports IEEE802.1Q tagging VLAN. Up to 256 groups of VLAN can be registered. (15) Supports IEEE802.1X user authentication function (EAP-MD5/TLS/PEAP). (16) Supports ZERUO assist Plus. Processes from introduction to maintenance can be performed easily. 			
Date issued	July 12, 2016	Panasonic Electric Works Networks Co., Ltd.	
Date revised	Apr 1, 2022		

Model Name	Switch-M16eG	Product Specification	401-28160K-SG-SP03
Model No.	PN28160K-SG		Page 2 of 10

3. Rated/Environmental Conditions

3-1. Power supply	AC100-240V, 50/60Hz, 0.5A (with a built-in power supply)
3-2. Power consumption	Normally, Max.11.7W, Min.4.8W
3-3. Operating environment	Temperature: 0 - 50°C Humidity: 20 - 80%RH (no condensation)
3-4. Storage environment	Temperature: -20 - 70°C Humidity: 10 - 90%RH (no condensation)
3-5. EMC compliance	CISPR 22 EN 55022 Class A AS/NZS CISPR22 Class A VCCI Class A EN 61000-3-2, EN 61000-3-3 CISPR 24 EN 55024 IEC 61000-4-2, IEC 61000-4-3, IEC 61000-4-4, IEC 61000-4-5, IEC 61000-4-6, IEC 61000-4-8, IEC 61000-4-11
3-6. Safety compliance	IEC 62368-1 EN 62368-1
3-7. Environment compliance	RoHS compliant

4. Form

4-1. Form and materials/colors	Dimensions : 44mm (Height) × 330mm (Width) × 230mm (Depth) (Excluding protruding sections) Case material : SECC Color : Main unit: Green 03, Front face: Black 03, Face plate label: Black 04
4-2. Mass (Weight)	2,200g

Date issued	July 12, 2016	Panasonic Electric Works Networks Co., Ltd.
Date revised	Apr 1, 2022	

Model Name	Switch-M16eG	Product Specification	401-28160K-SG-SP03
Model No.	PN28160K-SG		Page 3 of 10

5. Hardware Specifications

5-1. Interface	<p>Twisted pair port 1-16 :RJ45 connector (*1) Transmitting and receiving network system :IEEE802.3 10BASE-T IEEE802.3u 100BASE-TX IEEE802.3ab 1000BASE-T</p> <p>Transmission speed :10/100Mbps, full/half duplex :1000Mbps, full duplex</p> <p>Compatible cable :Twisted pair cable (At least equivalent to EIA/TIA568 category 5e)</p> <p>Maximum transmission distance :100m</p> <p>Auto-Negotiation :Communication speed and full/half duplex are automatically recognized. The setting can be fixed to 10Mbps, 100Mbps, and full duplex or half duplex.</p> <p>*1 Embedded power saving mode detects the connection status automatically and saves power consumption to minimum.</p> <p>SFP extension slot 15,16 SFF-8472 (DMI:Diagnostic Monitoring Interface) *Select either of RJ45 or SFP for use</p> <p>Optional Accessories :1000BASE-SX SFP Module (PN54021K-SG) 1000BASE-LX SFP Module (PN54023K-SG)</p>
5-2. Switching mode	<p>Switching method :Store and Forward</p> <p>Switching capacity :32Gbps</p> <p>Packet transfer capability :Non-blocking Max 1,488,000pps/port (1000Mbps) Max 148,800pps/port (100Mbps) Max 14,880pps/port (10Mbps)</p> <p>MAC Address table :Max 8K entry/unit</p> <p>Buffer memory :512K Byte/unit</p> <p>Flow control :half-duplex Back pressure full-duplex IEEE802.3x</p> <p>Aging timeout :10 to 1,000,000 sec. (Default: 300 sec.)</p> <p>Jumbo frame supported :9KB</p> <p>Transmittable frames :EAP,BPDU</p>
5-3. Terminal emulator connection	<p>Console port :RJ45 connector 1 port</p> <p>Transmission mode :RS-232C (ITU-TS V.24)</p> <p>Emulation mode :VT100</p> <p>Communication configuration :9,600bps, 8bit, None Parity control, Stop bit 1 bit</p>

Date issued	July 12, 2016	Panasonic Electric Works Networks Co., Ltd.
Date revised	Apr 1, 2022	

5. Hardware Specifications

5-4. LED display

- (1) POWER (Power) LED
 - Green Light : Power is ON
 - Off : Power is OFF
- (2) ANY COL.(Collision) LED
 - Orange Light : During half-duplex operation, packet collision is occurring in either port.
- (3) STATUS/ECO (Status/ECO made) LED
 - Green Light : Operating in Status mode.
 - Green Blink : Operating in ECO mode.
 - All port LEDs (left) are turned off.
 - Orange Light : Starting
 - Orange Blink : Malfunction (Contact the seller)
 - Off : Power is OFF.
- (4) GIGA (GIGA mode) LED
 - Green Light : Operating in GIGA mode.
- (5) 100M (Speed mode)
 - Green Light : Operating in Speed mode.
- (6) FULL (DUPLEX mode) LED
 - Green Light : Operating in DUPLEX mode.
- (7) LOOP HISTORY (Loop History mode) LED
 - Green Light : Operating in Loop History mode.
 - Green Blink : Loop is occurring, or occurred within the last 3days.

Display of each port is refer to table 1 of No.4 .

You can display the following items using the LED display change button. Display for the connection with a connected terminal (Status mode), Display for the 1000 Mbps transmission rate (GIGA mode) , Display for the 100Mbps or 10 Mbps transmission rate (Speed mode), Display for the full-duplex or half-duplex transmission system (DUPLEX mode), Display for ports with a loop history (Loop history mode), All port LED lamps can be turned OFF (ECO mode).

The mode at the start is called "Base mode".

There are two types of Base modes : Status mode (factory default setting) and ECO mode. You can change the Base mode by holding down the LED display change button (for at least 3 sec).

When the Base mode is changed normally, all STATUS/ECO , GIGA , 100M , and FULL LED lamps light up at the same time. When you release the button, the Base mode is changed to the selected mode.

If the mode is changed to the GIGA mode, Speed mode , DUPLEX mode, or Loop History mode and the LED display switch button is not used for one minute or longer, the mode automatically returns to a Base mode (Status mode or ECO mode). The Base mode is maintained even after the power is turned OFF.

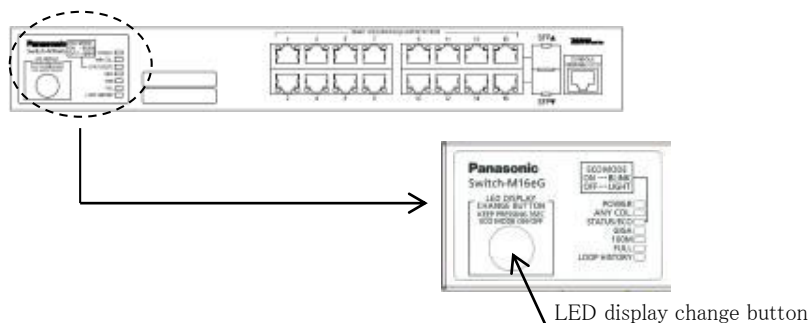

Date issued July 12, 2016

Date revised Apr 1, 2022

Panasonic Electric Works Networks Co., Ltd.

5. Hardware Specifications

5-4. LED display

Switch two types of Base mode s and their LEDs in the following way:

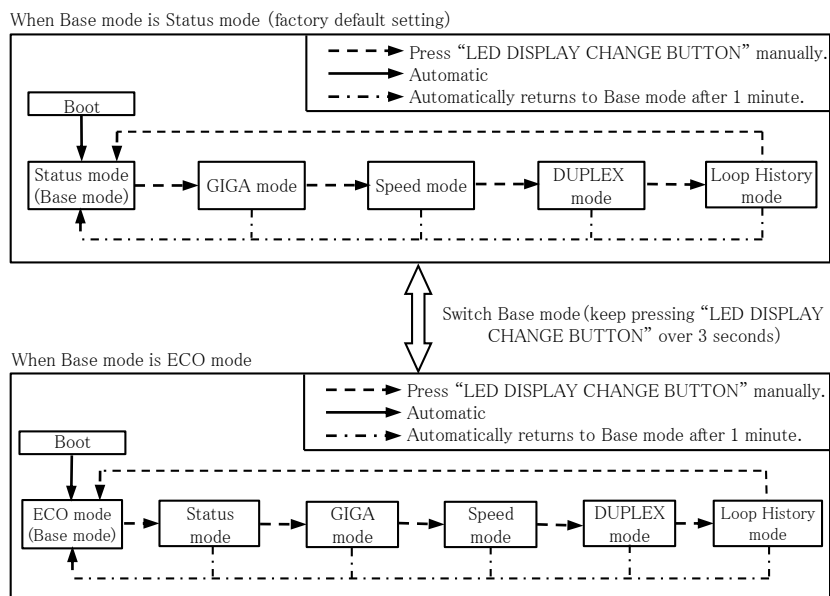

LED lamps for each mode and LED lamps for ports 1 to 16 correspond as the following. (Table 1)

Table 1

Port LED	Display mode	Behavior	Description
Left	STATUS/ECO	Green Light Green Blink Off	Link is established Transmitting and receiving data. No device connected.
	GIGA	Green Light Off	Link is established at 1000Mbps. Link is established at 100Mbps or 10Mbps , or no device is connected.
	100M	Green Light Off	Link is established at 100Mbps. Link is established at 1000Mbps or 10Mbps , or no device is connected.
	Full	Green Light Off	Link is established at full-duplex. Link is established at half-duplex or or no device is connected.
	LOOP HISTORY	Green Light Off	Loop has been detected within the last 3 days. No loop detection history.
Right	-	Orange Light Off	Shutting down by loop detection. Not shutting down by loop detection.

Port LED (Left)

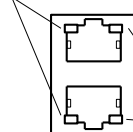

Port LED (Right)

Date issued July 12, 2016

Date revised Apr 1, 2022

Panasonic Electric Works Networks Co., Ltd.

Model Name	Switch-M16eG	Product Specification	401-28160K-SG-SP03
Model No.	PN28160K-SG		Page 6 of 10

6. Software Specifications

6-1. Configuration	Control parameters can be set by the following procedures: (1) Configuration from an asynchronous terminal connected to the console port. (2) Configuration from a remote terminal connected via TELNET and SSH																												
6-2. Ethernet Switch Control	Ethernet Switch can be controlled by the following procedures: (1) Control from an asynchronous terminal connected to the console port. (2) Control from a remote terminal using SSH/TELNET and TCP/IP network connection (3) Control using SNMP Manager The Ethernet Switch operation status can be checked using the following functions. (1) Function to display the CPU usage and memory usage (2) SFP module status checking function (DDM: Digital Diagnostic Monitoring)																												
6-3. Rebooting	The system can be reset from the software in the following three modes: (1) Warm start (2) Reset to factory default (3) Reset items other than the IP address to factory default The reboot timer function can also be used in each mode.																												
6-4. Supported Agent	<table border="0"> <tr> <td>Management protocol</td> <td>:SNMP v1/v2c/v3 (RFC1157,RFC1901, RFC1908)</td> </tr> <tr> <td></td> <td>TELNET (RFC854)</td> </tr> <tr> <td></td> <td>SSH v2 (RFC4251,RFC4252, RFC4253,RFC4254)</td> </tr> <tr> <td></td> <td>SNTP v3 (RFC1769)</td> </tr> <tr> <td>Data transfer protocol</td> <td>:TFTP (RFC783,RFC1350)</td> </tr> </table>	Management protocol	:SNMP v1/v2c/v3 (RFC1157,RFC1901, RFC1908)		TELNET (RFC854)		SSH v2 (RFC4251,RFC4252, RFC4253,RFC4254)		SNTP v3 (RFC1769)	Data transfer protocol	:TFTP (RFC783,RFC1350)																		
Management protocol	:SNMP v1/v2c/v3 (RFC1157,RFC1901, RFC1908)																												
	TELNET (RFC854)																												
	SSH v2 (RFC4251,RFC4252, RFC4253,RFC4254)																												
	SNTP v3 (RFC1769)																												
Data transfer protocol	:TFTP (RFC783,RFC1350)																												
6-5. Supported MIB	<table border="0"> <tr> <td>RFC1213-MIB (MIB II)</td> <td>(RFC 1213) (*1)</td> </tr> <tr> <td>BRIDGE-MIB</td> <td>(RFC 4188) (*2)</td> </tr> <tr> <td>SNMPv2-MIB</td> <td>(RFC 1907)</td> </tr> <tr> <td>RMON-MIB</td> <td>(RFC 2819) Only etherStatsTable</td> </tr> <tr> <td>SNMP-FRAMEWORK-MIB</td> <td>(RFC 2571)</td> </tr> <tr> <td>SNMP-MPD-MIB</td> <td>(RFC 2572)</td> </tr> <tr> <td>SNMP-NOTIFICATION-MIB</td> <td>(RFC 2573N)</td> </tr> <tr> <td>SNMP-TARGET-MIB</td> <td>(RFC 2573T)</td> </tr> <tr> <td>SNMP-USER-BASED-SM-MIB</td> <td>(RFC 2574)</td> </tr> <tr> <td>SNMP-VIEW-BASED-ACM-MIB</td> <td>(RFC 2575)</td> </tr> <tr> <td>SNMP-COMMUNITY-MIB</td> <td>(RFC 2576)</td> </tr> <tr> <td>IP-MIB</td> <td>(RFC 4293) (*3)</td> </tr> <tr> <td>IF-MIB</td> <td>(RFC 2233) Excluding IfMIB</td> </tr> <tr> <td>IEEE8021-PAE-MIB</td> <td>Excluding dot1xPaeSupplicant</td> </tr> </table> <p>*1 Excluding following item At, ipRouteTable, icmp, egp</p> <p>*2 Excluding following item dot1dStp, dot1dSr, dot1dStatic</p> <p>*3 Excluding following item ipDefaultRouterTable, ipv6RouterAdvertTable</p>	RFC1213-MIB (MIB II)	(RFC 1213) (*1)	BRIDGE-MIB	(RFC 4188) (*2)	SNMPv2-MIB	(RFC 1907)	RMON-MIB	(RFC 2819) Only etherStatsTable	SNMP-FRAMEWORK-MIB	(RFC 2571)	SNMP-MPD-MIB	(RFC 2572)	SNMP-NOTIFICATION-MIB	(RFC 2573N)	SNMP-TARGET-MIB	(RFC 2573T)	SNMP-USER-BASED-SM-MIB	(RFC 2574)	SNMP-VIEW-BASED-ACM-MIB	(RFC 2575)	SNMP-COMMUNITY-MIB	(RFC 2576)	IP-MIB	(RFC 4293) (*3)	IF-MIB	(RFC 2233) Excluding IfMIB	IEEE8021-PAE-MIB	Excluding dot1xPaeSupplicant
RFC1213-MIB (MIB II)	(RFC 1213) (*1)																												
BRIDGE-MIB	(RFC 4188) (*2)																												
SNMPv2-MIB	(RFC 1907)																												
RMON-MIB	(RFC 2819) Only etherStatsTable																												
SNMP-FRAMEWORK-MIB	(RFC 2571)																												
SNMP-MPD-MIB	(RFC 2572)																												
SNMP-NOTIFICATION-MIB	(RFC 2573N)																												
SNMP-TARGET-MIB	(RFC 2573T)																												
SNMP-USER-BASED-SM-MIB	(RFC 2574)																												
SNMP-VIEW-BASED-ACM-MIB	(RFC 2575)																												
SNMP-COMMUNITY-MIB	(RFC 2576)																												
IP-MIB	(RFC 4293) (*3)																												
IF-MIB	(RFC 2233) Excluding IfMIB																												
IEEE8021-PAE-MIB	Excluding dot1xPaeSupplicant																												
6-6. System log	Maximum number to be kept: 256 System log transfer (IPv4/IPv6)																												

Date issued	July 12, 2016	Panasonic Electric Works Networks Co., Ltd.
Date revised	Apr 1, 2022	

Model Name	Switch-M16eG	Product Specification	401-28160K-SG-SP03
Model No.	PN28160K-SG		Page 7 of 10

6. Software Specifications

6-7. Loop detection	<p>Turns on the port LED with a orange light when a loop occurs in the corresponding port. At this time, the relevant port automatically shuts down to prevent loop from occurring. SNMP trap can be sent to notify the incident to the administrator. During loop is occurring, or if loop has occurred within the latest 3 days, LOOP HISTORY LED blinks to notify this.</p> <ul style="list-style-type: none"> · Loop detection setting <ul style="list-style-type: none"> Enabled (factory default setting) Enabled/disabled can be switched by configuring a setting using the console, or by pressing "LED DISPLAY CHANGE BUTTON" for 10 seconds or more. The setting is kept even when the power is turned OFF. · Loop detection port <ul style="list-style-type: none"> Enabled: Ports 1 to 14 (factory default setting) Disabled: Ports 15 and 16 (factory default setting) · Loop shutoff time <ul style="list-style-type: none"> 60 to 86,400 sec. (Factory default setting: 60 sec.) The set time Port LED lights up orange and the port shuts off. · Loop history retention time <ul style="list-style-type: none"> 3 days The LOOP HISTORY LED lamp flashes for three days. The Port LED lamp also remains lit for three days after the loop is eliminated.
6-8. Others	<p>ZEQUO assist Plus Syslog Client (Transfers system logs to the Syslog server.) TFTP Client (Upgrades the software and saves/loads configuration information.) Login RADIUS (login authentication function by the RADIUS server)</p>

7. Layer 2 Switching Functions

7-1. Port grouping	<p>Members of the port group can communicate only among member ports in the same group. (Number of group registrations: 256)</p>
7-2. VLAN	<p>IEEE802.1Q Tag VLAN Protocol Port Base VLAN Number of VLAN registrations: 256 (including default) Internet Mansion function</p>
7-3. Trunking	<p>IEEE802.ad Link Aggregation function (STATIC) Up to 8 groups can be created (up to 8 ports per group).</p>
7-4. Port Monitoring	<p>Traffic of the target port can be copied to the specified port and transmitted. (Two or more target ports can be specified.)</p>
7-5. QoS	<p>IEEE802.1p 4 levels of Priority Queue supported (Strict priority queuing)</p>
7-6. Authentication Function	<p>IEEE802.1X Port-based authentication (EAP-MD5/TLS/PEAP Authentication method)</p>
7-7. Access control	<p>Access control can be controlled by the following parameters:</p> <ol style="list-style-type: none"> (1) IP address (Source or Destination) (2) IPv6 address (Source or Destination) (3) MAC address (Source or Destination) (4) TCP/UDP port number (Source or Destination) (5) VLAN ID (6) IEEE 802.1p Priority (7) DSCP (8) Protocol (9) ICMP type (10) TCP SYN Flag
7-8. Time configuration	<p>SNTP-based time synchronization function Manual mode setting</p>

Date issued	July 12, 2016	Panasonic Electric Works Networks Co., Ltd.
Date revised	Apr 1, 2022	

Model Name	Switch-M16eG	Product Specification	401-28160K-SG-SP03
Model No.	PN28160K-SG		Page 8 of 10

8. Connector Pin Arrangement

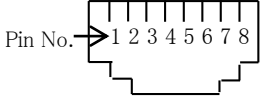
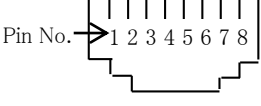
8-1. Port 1 - 16										
Status	Pin No.		1	2	3	6	4	5	7	8
MDI-X	Signal		BLDB+	BLDB-	BLDA+	BLDA-	BLDD+	BLDD-	BLDC+	BLDC-
MDI	Signal	BLDA+	BLDA-	BLDB+	BLDB-	BLDC+	BLDC-	BLDD+	BLDD-	
8-2. Console port										
Pin No.	Signal		Pin No.	Signal						
1	NC		5	GND						
2	NC		6	RXD						
3	TXD		7	NC						
4	GND	8	NC							

9. Installation Procedures and Accessories

9-1. Installation Procedures	Mounting to rack
9-2. Accessories	(1) Installation Guide :1 (2) Mounting bracket (for 19-inch rack) :2 (3) Screw (for 19-inch rack) :4 (4) Screw (for fixing the main unit and the 19 inch rack mount bracket) :8 (5) Rubber foot :4 (6) Power cord (BS1363)(*) :1 * The attached power cord is dedicated for AC 100 - 240 V use.

10. Optional Accessories

10-1. 1000BASE-SX SFP Module (Model No.:PN54021K-SG)	Fiber optic port connector type :LC connector (Duplex) Standards :IEEE802.3z 1000BASE-SX Transmission speed :1000Mbps, full duplex Compatible cable :Fiber cable 50/125 μ m Multi Mode Fiber 62.5/125 μ m Multi Mode Fiber Maximum transmission distance :550 m at 50/125 μ m 220 m at 62.5/125 μ m
10-2. 1000BASE-LX SFP Module (Model No.:PN54023K-SG)	Fiber optic port connector type :LC connector (Duplex) Standards :IEEE802.3z 1000BASE-LX Transmission speed :1000Mbps, full duplex Compatible cable :Fiber cable 10/125 μ m Single Mode Fiber 50/125 μ m Multi Mode Fiber 62.5/125 μ m Multi Mode Fiber Maximum transmission distance :10 km when Single Mode Fiber is used 550 m when Multi Mode Fiber is used

Date issued	July 12, 2016	Panasonic Electric Works Networks Co., Ltd.
Date revised	Apr 1, 2022	

Model Name	Switch-M16eG	Product Specification	401-28160K-SG-SP03
Model No.	PN28160K-SG		Page 9 of 10

11. Prohibitions when Using the Product to Guarantee Safety

The manufacturer assumes no responsibility for any problems occurring when the following conditions are not satisfied. Observe the following items when using the product.

- (1) Do not use power supply other than AC 100 – 240 V.
Deviation could lead to fire, electric shock, and/or equipment failure.
- (2) Do not handle the power cord with wet hand.
Deviation could lead to electric shock, and/or equipment failure.
- (3) Do not handle this Ethernet Switch and connection cables during a thunderstorm.
Deviation could lead to electric shock.
- (4) Do not disassemble and/or modify this Ethernet Switch.
Deviation could lead to fire, electric shock, and/or equipment failure.
- (5) Do not damage the power cord. Do not bend too tightly, stretch, twist, bundle with other cord, pinch, put under a heavy object and/or heat it.
Damaged power cord could lead to fire, short, and/or electric shock.
- (6) Do not unplug nor plug in the power plug with wet hands.
Deviation could lead to electrical shock, and/or equipment failure.
- (7) Do not insert nor drop any foreign objects such as metal or readily combustible things into the inside through the openings.
Deviation could lead to fire, electrical shock, and/or equipment failure.
- (8) Do not store or use the Ethernet Switch in places where it might get splashed with liquids such as water, in places with a lot of humidity, in places with conductive dust, or in places where there are corrosive and combustible gases.
Deviation could lead to fire, electrical shock, and/or equipment failure.
- (9) Do not store or use the Ethernet Switch in places where it will be exposed to direct sunlight or high temperatures.
The temperature inside will rise, which may cause fire.
- (10) Do not store or use the Ethernet Switch in places where there are lots of vibrations and impacts, or in unstable areas.
It might fall, which may cause injuries and/or equipment failure.
- (11) Do not put the Ethernet Switch into fire.
Deviation could lead to explosion and/or fire.
- (12) Do not insert nor drop any foreign objects such as metal or readily combustible things into the inside through the openings, twisted pair ports, console ports, SFP extension slots, or SD card slots.
Deviation could lead to fire, electrical shock, and/or equipment failure.

12. Basic Instructions for the Use of This Product

- (1) Handle the Ethernet Switch carefully so that fingers or hands may not be damaged by twisted pair port, SFP extension slot, console port, or power cord hook block.
- (2) Do not connect any other devices except for 10BASE-T/100BASE-TX/1000BASE-T devices to the twisted pair ports.
Deviation could lead to equipment failure.
- (3) Do not mount any other modules except for the separately sold SFP module (PN54021K/PN54023K) to the SFP extension slots.
- (4) Unplug the power plug when there is a malfunction.
Deviation could lead to fire if the power is allowed to be supplied for extended periods of time.
- (5) Be sure to connect the ground cable.
-Otherwise this might cause electrical shocks, misoperations and malfunctions.
-Connect the Ethernet Switch via the supplied power cord to the outlet which is connected to the ground.
-If the outlet is not connected to a ground, connect the ground cable to the ground terminal screw.

Date issued	July 12, 2016	Panasonic Electric Works Networks Co., Ltd.
Date revised	Apr 1, 2022	

Model Name	Switch-M16eG	Product Specification	401-28160K-SG-SP03
Model No.	PN28160K-SG		Page 10 of 10
<p>11. Prohibitions when Using the Product to Guarantee Safety</p> <p>(6) Use the bundled power cord (AC 100 - 240 V specifications). Deviation could lead to electric shock, malfunction, and/or equipment failure.</p> <p>(7) Unplug the power cord in case of equipment failure. Deviation, such as keeping connected for a long time, could lead to fire.</p> <p>(8) Connect this Ethernet Switch to ground. Deviation could lead to electric shock, malfunction, and/or equipment failure.</p> <p>(9) Connect the power cord firmly to the power port. Deviation could lead to electric fire, shock, and/or malfunction.</p> <p>(10) Unplug the power cord if the STATUS LED blinks in orange (system fault). Deviation, such as keeping connected for a long time, could lead to fire.</p> <p>(11) This Ethernet Switch is to be periodically serviced in order to maintain its performance. Please choose a product administrator, and have them be sure to implement periodic maintenance. When doing maintenance, check the inspection chart that is posted on our website which has the requisite items listed on it.</p> <p>(12) When using this Ethernet Switch to design systems, use it after applying appropriate measures such as setting up redundant configurations. Communications failures might be generated due to causes such as malfunctions or misoperations while the Ethernet Switch is being used.</p> <p>(13) When using this Ethernet Switch for applications which require extremely high reliability, be careful to expend all possible means to ensure safety and reliability. This Ethernet Switch was not designed nor manufactured with the intention that it be used for applications (in use with railways, aviation, and medical care, etc. whereas the influence rate due to communications failures is extremely high in regard to systems that directly affect systems and human lives) which require extremely high reliability.</p> <p>(14) It is strongly recommended that a lightning arrester (SPD) be installed on the twisted pair port side and the power supply side of this Ethernet Switch. Malfunctions might be caused due to overcurrent and overvoltage due to the effects of lightning strikes.</p> <p>(15) It is recommended that this Ethernet Switch be replaced about five years after it has been installed. This may vary depending upon conditions such as utilisation rates and usage environments, but performance might decrease due to the age-related degradation, etc. of components.</p> <p>(16) Be careful in regards to environmental restrictions whereby the Ethernet Switch can be used. Please isolate the business power lines and communications lines. Isolate distribution lines and other distribution lines, and low current power lines, optical fiber cables, metallic water conduits, and gas conduits, etc. Noise may be generated in the communications lines which might cause communications glitches.</p>			
Date issued	July 12, 2016	Panasonic Electric Works Networks Co., Ltd.	
Date revised	Apr 1, 2022		