

Model Name	Switch-M8eGi	Product Specification	401-28080i-TH-SP03
Model No.	PN28080i-TH		Page 1 of 13
<p>1. Summary</p> <p>Switch-M8eGi is an all Giga bit Ethernet Switch with management function having 8 ports of 10/100/1000BASE-T and SFP extension slot.</p> <p>2. Feature</p> <p>(1) Has wire speed layer 2 switching functions.</p> <p>(2) Ports 1 to 8 are auto negotiation-ready 10/100/1000BASE-T ports. Their speed and communication mode can be changed by configuration. Port 9 can be exclusively used as an SFP extension slot.</p> <p>(3) All twisted pair ports support straight/cross cable auto sensing function. Simply connect devices with straight cables, whether it is a terminal or a network device.(This function does not work if the port communication configuration is set at Fixed or Link Aggregation. Ports 1 to 8 are set at MDI-X. (default))</p> <p>(4) Due to the loop detection/shutoff function, a port where loop has occurred can be automatically shut off to prevent loop failures. When a port is shut off and recovered automatically, SNMP trap can be sent to notify the incident to the administrator. Moreover, the port with a loop can be identified by loop notification on the LEDs on the main unit and referring the history of loop on the setting screen.</p> <p>(5) Has a loop detection history function, which notifies when a loop occurs with the corresponding LED and enables a network administrator to identify the looped port after the loop is removed.</p> <p>(6) Fanless design solves noise problem or fan failure.</p> <p>(7) Power consumption can be suppressed by switching off the port LEDs (left) via the ECO mode LED functions.</p> <p>(8) The IEEE802.1p compatible QoS function is supported.</p> <p>(9) Has an Internet Mansion function, which ensures security between each door.</p> <p>(10) Has a port grouping function, which groups ports that are allowed to communicate with one another to limit communications between different groups.</p> <p>(11) Equipped with energy efficient Ethernet (EEE) conforming to IEEE802.3az (LPI). When there is no data transmission at link up, the energy-saving state automatically starts so that power consumption can be reduced on each port. Factory default : Disable</p> <p>(12) Embedded power saving mode detects the connection status automatically and saves power consumption to minimum. Factory default : Disable</p> <p>(13) VLAN function allows free grouping of up to 256 VLANs.</p> <p>(14) IEEE802.1Q VLAN tagging is supported, and a maximum of 256 VLANs can be registered.</p> <p>(15) The IEEE802.1X compatible user authentication function (EAP-MD5/TLS/PEAP) is supported.</p> <p>(16) Each single port supports IEEE 802.1X, Web, and MAC authentication protocols, eliminating the need for individually setting the ports' authentication parameters.</p> <p>(17) Supports ZEUQUO assist Plus. Processes from introduction to maintenance can be performed easily.</p>			
Date issued	Oct. 01, 2019	Panasonic Electric Works Networks Co., Ltd.	
Date revised	Apr. 01, 2022		

Model Name	Switch-M8eGi	Product Specification	401-28080i-TH-SP03
Model No.	PN28080i-TH		Page 2 of 13

### 3. Rated/Environmental Conditions

3-1. Power supply	AC100-240V, 50/60Hz, 0.5A (with a built-in power supply)
3-2. Power consumption	Normally, Max : 6.2W, Min : 2.4W
3-3. Operating environment	Temperature: 0 - 60°C Humidity: 20 - 80%RH (no condensation)
3-4. Storage environment	Temperature: -20 - 70°C Humidity: 10 - 90%RH (no condensation)
3-5. EMC compliance	CISPR 22 Class A EN 55022 Class A AS/NZS CISPR22 Class A VCCI Class A EN 61000-3-2, EN 61000-3-3 CISPR 24 EN 55024 IEC 61000-4-2, IEC 61000-4-3, IEC 61000-4-4, IEC 61000-4-5, IEC 61000-4-6, IEC 61000-4-8, IEC 61000-4-11
3-6. Safety compliance	IEC 62368-1 EN 62368-1
3-7. Environment compliance	RoHS compliant

### 4. Form

4-1. Form and materials/colors	Dimensions : 44mm (Height) × 210mm (Width) × 130mm (Depth) (Excluding protruding sections) Case material : SECC Color : Main unit: Green 03, Front face: Black 03, Face plate label: Black 04
4-2. Mass (Weight)	1,100g

Date issued	Oct. 01, 2019	Panasonic Electric Works Networks Co., Ltd.
Date revised	Apr. 01, 2022	

## 5. Hardware Specifications

5-1. Interface	<p>Twisted pair port 1-8 :RJ45 connector (*1)  Transmitting and receiving network system:  IEEE802.3 10BASE-T  IEEE802.3u 100BASE-TX  IEEE802.3ab 1000BASE-T</p> <p>Energy Efficient Ethernet (*2) :IEEE802.3az (LPI)  Transmission speed :10/100Mbps, full/half duplex  :1000Mbps, full duplex  Compatible cable :Twisted pair cable  (At least equivalent to EIA/TIA568 category 5e)</p> <p>Maximum transmission distance :100m  Auto-Negotiation :Communication speed and full/half duplex  are automatically recognized.  The setting can be fixed to 10Mbps,  100Mbps, and full duplex or half duplex.</p> <p>*1 Embedded power saving mode detects the connection status automatically  and saves power consumption to minimum.  Factory default : Disable</p> <p>*2 Energy Efficient Ethernet (EEE) conforming to IEEE802.3az (LPI).  When there is no data transmission at link up, the energy-saving state  automatically starts so that power consumption can be reduced on each port.  Factory default : Disable</p> <p>SFP extension slot 9  Transmitting and receiving network system:  :IEEE802.3z 1000BASE-SX/LX  SFF-8472 (DMI:Diagnostic Monitoring Interface)  Optional Accessories :1000BASE-SX SFP Module (i) (PN54022-TH)  1000BASE-LX SFP Module (i) (PN54024-TH)</p>
5-2. Switching mode	<p>Switching method :Store and Forward  Switching capacity :18Gbps  Packet transfer capability :Non-blocking  Max 1,488,000pps/port (1000Mbps)  Max 148,800pps/port (100Mbps)  Max 14,880pps/port (10Mbps)</p> <p>MAC Address table :Max 8K entry/unit  Buffer memory :512K Bytes/unit  Flow control :half-duplex Back pressure  full-duplex IEEE802.3x</p> <p>Aging timeout :10 to 100,000 sec. (Default: 300 sec.)  Jumbo frame supported :9KB  Transmittable frames :EAP,BPDU  HOL Blocking Prevention :Support</p>
5-3. Terminal emulator connection	<p>Console port :RJ45 connector 1 port  Transmission mode :RS-232C (ITU-TS V.24)  Emulation mode :VT100  Communication configuration :9,600bps, 8bit, None Parity control,  Stop bit 1 bit</p>

## 5. Hardware Specifications

### 5-4. LED display

- (1) POWER (Power) LED
  - Green Light : Power is ON
  - Off : Power is OFF
- (2) ANY COL. (Collision) LED
  - Orange Light : During half-duplex operation, packet collision is occurring in either port.
- (3) STATUS/ECO (Status/ECO mode) LED
  - Green Light : Operating in status mode.
  - Green Blink : Operating in ECO mode.  
All port LEDs (left) are turned off.
  - Orange Light : Starting
  - Orange Blink : Malfunction (Contact the seller)
  - Off : Power is OFF.
- (4) GIGA (GIGA mode) LED
  - Green Light : Operating in GIGA mode.
- (5) 100M (Speed mode) LED
  - Green Light : Operating in Speed mode.
- (6) FULL (DUPLEX mode) LED
  - Green Light : Operating in DUPLEX mode.
- (7) LOOP HISTORY (Loop History mode) LED
  - Green Light : Operating in Loop History mode.
  - Green Blink : Loop is occurring,  
or occurred within the last 3days.

Display of each port is refer to table 1 of No.5.

You can display the following items using the LED display change button.  
 Display for the connection with a connected terminal (Status mode), Display for the 1000 Mbps transmission rate (GIGA mode), Display for the 100Mbps or 10 Mbps transmission rate (Speed mode), Display for the full-duplex or half-duplex transmission system (DUPLEX mode), Display for ports with a loop history (Loop history mode), All port LED lamps can be turned OFF (ECO mode).

The mode at the start is called "Base mode".

There are two types of Base modes : Status mode (factory default setting) and ECO mode. You can change the Base mode by holding down the LED display change button (for at least 3 sec).

When the Base mode is changed normally, all STATUS/ECO, GIGA, 100M, and FULL LED lamps light up at the same time. When you release the button, the Base mode is changed to the selected mode.

If the mode is changed to the GIGA mode, Speed mode, DUPLEX mode, or Loop History mode and the LED display switch button is not used for one minute or longer, the mode automatically returns to a Base mode (Status mode or ECO mode). The Base mode is maintained even after the power is turned OFF.

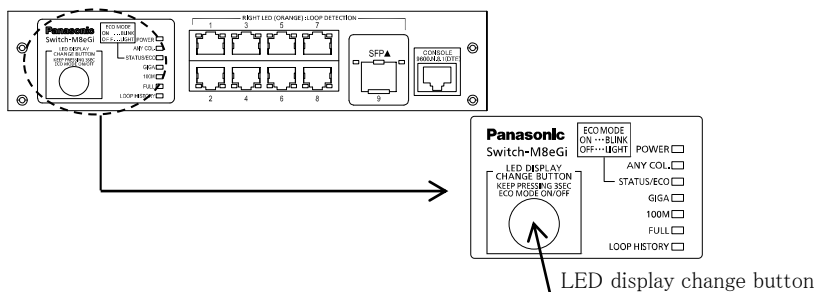

## 5. Hardware Specifications

### 5-4. LED display

Switch two types of Base mode s and their LEDs in the following way:

When Base mode is Status mode (factory default setting)

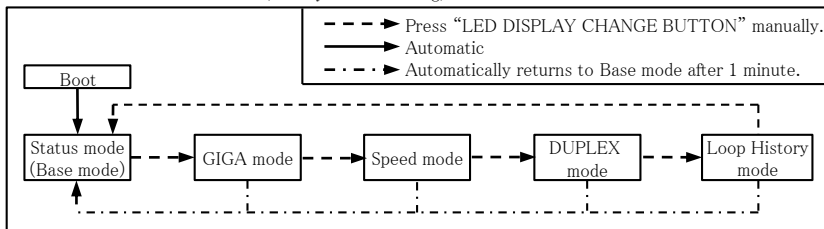

Switch Base mode (keep pressing "LED DISPLAY CHANGE BUTTON" over 3 seconds)

When Base mode is ECO mode

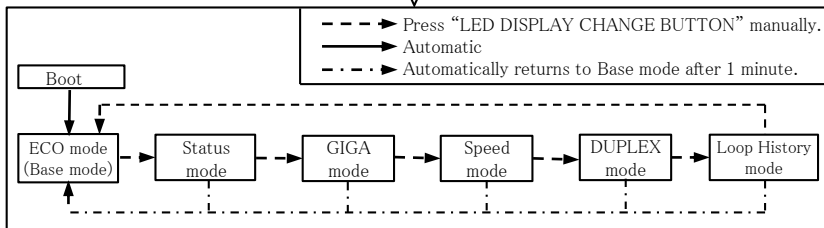

LED lamps for each mode and LED lamps for ports 1 to 9 correspond as the following. (Table 1)

Table 1

Port LED	Display mode	Behavior	Description
Left	STATUS/ECO	Green Light Green Blink Off	Link is established Transmitting and receiving data. No device connected.
	GIGA	Green Light Off	Link is established at 1000Mbps. Link is established at 100Mbps or 10Mbps , or no device is connected.
	100M	Green Light Off	Link is established at 100Mbps. Link is established at 1000Mbps or 10Mbps , or no device is connected.
	Full	Green Light Off	Link is established at full-duplex. Link is established at half-duplex or no device is connected.
	LOOP HISTORY	Green Light Off	Loop has been detected within the last 3 days. No loop detection history.
Right	—	Orange Light Off	Shutting down by loop detection. Not shutting down by loop detection.

Port LED (Left)

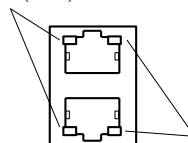

Port LED (Right)

### 5-5. Cascade connections

Port 1-8 corresponding to the Auto MDI / MDI-X (Allowed change by the setting for the application)  
Ports 1-7 are set to "Disable" at factory default setting.

### 5-6. Fan

Fan-less

Date issued

Oct. 01, 2019

Date revised

Apr. 01, 2022

Panasonic Electric Works Networks Co., Ltd.

Model Name	Switch-M8eGi	Product Specification	401-28080i-TH-SP03
Model No.	PN28080i-TH		Page 6 of 13

## 6. Software Specifications

6-1. Configuration	Control parameters can be set by the following procedures: (1) Configuration from an asynchronous terminal connected to the console port. (2) Configuration from a remote terminal connected via TELNET and SSH (3) It can be set from a remote terminal according to the Web screen.
6-2. Ethernet Switch Control	It is possible to check the control and operation of the Ethernet Switch by ZEQUO assist Plus. Ethernet Switch can be controlled by the following procedures: (1) Control from an asynchronous terminal connected to the console port. (2) Control from a remote terminal using SSH/TELNET and TCP/IP network connection (3) Control using SNMP Manager The Ethernet Switch operation status can be checked using the following functions. (1) Function to display the CPU (2) SFP module status checking function (DDM: Digital Diagnostic Monitoring)
6-3. Rebooting	The system can be reset from the software in the following three modes: (1) Warm start (2) Reset to factory default (3) Reset items other than the IP address to factory default The reboot timer function can also be used in each mode.
6-4. Supported Agent	Management protocol :SNMP v1/v2c/v3 (RFC1157,RFC1901, RFC1908) TELNET (RFC854) SSH v2 (RFC4251,RFC4252, RFC4253,RFC4254) SNTP v3 (RFC1769) Data transfer protocol :TFTP (RFC783,RFC1350)
6-5. Supported MIB	RFC1213-MIB (MIB II) (RFC 1213) (*1) BRIDGE-MIB (RFC 4188) (*2) SNMPv2-MIB (RFC 1907) RMON-MIB (RFC 2819) Only etherStatsTable SNMP-FRAMEWORK-MIB (RFC 2571) SNMP-MPD-MIB (RFC 2572) SNMP-NOTIFICATION-MIB (RFC 2573N) SNMP-TARGET-MIB (RFC 2573T) SNMP-USER-BASED-SM-MIB (RFC 2574) SNMP-VIEW-BASED-ACM-MIB (RFC 2575) SNMP-COMMUNITY-MIB (RFC 2576) IP-MIB (RFC 4293) (*3) IF-MIB (RFC 2233) Excluding IfMIB IEEE8021-PAE-MIB (IEEE802.1X) Excluding dot1xPaeSupplicant  *1 Excluding following item At , ipRouteTable, icmp, egp  *2 Excluding following item dot1dStp, dot1dSr, dot1dStatic  *3 Excluding following item ipDefaultRouterTable, ipv6RouterAdvertTable
6-6. System log	Maximum number to be kept: 256 System log transfer (IPv4/IPv6)

Date issued	Oct. 01, 2019	Panasonic Electric Works Networks Co., Ltd.
Date revised	Apr. 01, 2022	

Model Name	Switch-M8eGi	Product Specification	401-28080i-TH-SP03
Model No.	PN28080i-TH		Page 7 of 13

## 6. Software Specifications

6-7. Loop detection	<p>Turns on the port LED with a orange light when a loop occurs in the corresponding port. At this time, the relevant port automatically shuts down to prevent loop from occurring. SNMP trap can be sent to notify the incident to the administrator. During loop is occurring, or if loop has occurred within the latest 3 days, LOOP HISTORY LED blinks to notify this.</p> <ul style="list-style-type: none"> <li>· Loop detection port <ul style="list-style-type: none"> <li>Enabled: Ports 1 to 8 (factory default setting)</li> <li>Disabled: Port 9 (factory default setting)</li> </ul> </li> <li>· Loop detection setting <ul style="list-style-type: none"> <li>Enabled (factory default setting)</li> <li>Enabled/disabled can be switched by configuring a setting using the console, or by pressing "LED DISPLAY CHANGE BUTTON" for 10 seconds or more.</li> <li>The setting is kept even when the power is turned OFF.</li> </ul> </li> <li>· Loop shutoff time <ul style="list-style-type: none"> <li>60 to 86,400 sec. (Factory default setting: 60 sec.)</li> <li>The set time Port LED lights up orange and the port shuts off.</li> </ul> </li> <li>· Loop history retention time <ul style="list-style-type: none"> <li>3 days</li> <li>The LOOP HISTORY LED lamp flashes for three days.</li> <li>The Port LED lamp also remains lit for three days after the loop is eliminated.</li> </ul> </li> </ul> <p>The Loop shutoff mode has the following 2 types of modes.</p> <ul style="list-style-type: none"> <li>· Block mode (factory default setting) <ul style="list-style-type: none"> <li>When loops are detected, the ports are blocked, and just the loop detection packets will be transmitted and received.</li> </ul> </li> <li>· Shutdown mode <ul style="list-style-type: none"> <li>When loops are detected, the ports are shut down, and none of the packets including the loop detection packets will be transmitted nor received. (*)</li> <li>* Just the loop detection packets from 30 seconds before the set restoration times will automatically be transmitted and received.</li> </ul> </li> </ul>
6-8. Others	<p>Syslog Client (Transfers system logs to the Syslog server.) TFTP Client (Upgrades the software and saves/loads configuration information.) Login RADIUS (login authentication function by the RADIUS server)</p>

Date issued	Oct. 01, 2019	Panasonic Electric Works Networks Co., Ltd.
Date revised	Apr. 01, 2022	

Model Name	Switch-M8eGi	Product Specification	401-28080i-TH-SP03
Model No.	PN28080i-TH		Page 8 of 13

## 7. Layer 2 Switching Functions

7-1. Port grouping	Members of the port group can communicate only among member ports in the same group. (Number of group registrations: 256)
7-2. VLAN	IEEE802.1Q Tag VLAN Protocol Port Base VLAN, Guest VLAN, Dynamic VLAN Number of VLAN registrations: 256 (including default) Internet Mansion function
7-3. Trunking	IEEE802.ad Link Aggregation function (STATIC) Up to 4 groups can be created (up to 8 ports per group).
7-4. Port Monitoring	Traffic of the target port can be copied to the specified port and transmitted. (Two or more target ports can be specified.)
7-5. QoS	IEEE802.1p 4 levels of Priority Queue supported (Strict priority queuing )
7-6. Authentication Function	IEEE802.1X Port-based authentication (EAP-MD5/TLS/PEAP Authentication method) Web-based authentication, Mac-based authentication using IEEE 802.1X Web-based authentication, Dynamic VLAN function using IEEE 802.1X Guest VLAN using IEEE 802.1X Force Authorized MAC Address Configuration EAP Packet Forwarding function (Enable/disable EAP transmission can be specified for each port.) MAC authentication WEB authentication Triple authentication※ ※IEEE802.1X MAC-based/MAC/WEB authentication can be simultaneously
7-7. Access control	Access control can be controlled by the following parameters: (1) IP address (Source or Destination) (2) IPv6 address (Source or Destination) (3) MAC address (Source or Destination) (4) TCP/UDP port number (Source or Destination) (5) VLAN ID (6) IEEE 802.1p Priority (7) DSCP (8) Protocol (9) ICMP type (10) TCP SYN Flag
7-8. Time configuration	SNTP-based time synchronization function Manual mode setting
7-9. Others	FDB ARP table NDP table DDM (Digital Diagnostic Monitoring) Reboot (Normal/Default/Default-exceptIP) Statics IPv4 Ping Execution IPv6 Ping Execution Watch Dog Timer

Date issued	Oct. 01, 2019	Panasonic Electric Works Networks Co., Ltd.
Date revised	Apr. 01, 2022	



Model Name	Switch-M8eGi	Product Specification	401-28080i-TH-SP03
Model No.	PN28080i-TH		Page 9 of 13

## 8. Web management function

8-1. Software specification		
8-1-1. Enabled browser	Microsoft Internet Explorer 11	
8-2. Setting function		
8-2-1. Switching configuration	Administration IP Port System security Syslog transmission ID/Password Static ARP table VLAN seting QoS setting 802.1X Access Control Configuration	Link aggregation Storm control Port monitoring Static multicast address Port group System log Exception handler Watchdog Timer setting Loop detection and shutoff DDM
8-2-2. Time setting	SNTP setting, manual setting	
8-3. Monitoring function		
8-3-1. Basic information	System information, Hardware information, Management information[Host name (sysName)], System address information	
8-3-2. Learning and recording information	FDB table, ARP table, Statistics, System log	
8-4. System management	Software upgrade, Reboot, Save current config, file transfer, Ping execution	

## 9. Connector Pin Arrangement

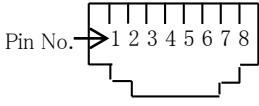
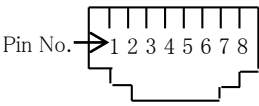
9-1. Port 1 - 8										
Status	Pin No.	1	2	3	6	4	5	7	8	
MDI-X	Signal	BL_DB+	BL_DB-	BL_DA+	BL_DA-	BL_DD+	BL_DD-	BL_DC+	BL_DC-	
MDI	Signal	BL_DA+	BL_DA-	BL_DB+	BL_DB-	BL_DC+	BL_DC-	BL_DD+	BL_DD-	
9-2. Console port										
Pin No.	Signal			Pin No.	Signal					
1	NC			5	GND					
2	NC			6	RXD					
3	TXD			7	NC					
4	GND			8	NC					

## 10. Installation Procedures and Accessories

10-1. Installation Procedures	(1) Mounting to wall (2) Mounting to rack	
10-2. Accessories	(1) Installation Guide (English) (2) Installation Guide (Thai) (3) Rubber foot (4) Wall mount bracket (5) Screw (for fixing the wall mount brackets to the Ethernet Switch) (6) Rack mount bracket (for 19-inch rack) (7) Connection bracket(for connection two Ethernet Switches) (8) Screw (for 19-inch rack) (9) Screw (for fixing the mount brackets to the Ethernet Switch) (10) Screw (for fixing the connection bracket) (11) Power cord (BS1363) (*)	:1 :1 :4 :2 :8 :2 :2 :4 :8 :8 :1
* The attached power cord is dedicated for AC 100 - 240 V use.		

Date issued	Oct. 01, 2019	Panasonic Electric Works Networks Co., Ltd.
Date revised	Apr. 01, 2022	

Model Name	Switch-M8eGi	Product Specification	401-28080i-TH-SP03
Model No.	PN28080i-TH		Page 10 of 13

### 11. Optional Accessories

<p>11-1. 1000BASE-SX SFP Module (i) (Model No.:PN54022-TH)</p>	<p>Fiber optic port connector type :LC connector (Duplex)</p> <p>Standards :IEEE802.3z 1000BASE-SX</p> <p>Transmission speed :1000Mbps, full duplex</p> <p>Compatible cable :Fiber cable 50/125 <math>\mu</math> m Multi Mode Fiber 62.5/125 <math>\mu</math> m Multi Mode Fiber</p> <p>Maximum transmission distance :550 m at 50/125 <math>\mu</math> m 220 m at 62.5/125 <math>\mu</math> m</p>
<p>11-2. 1000BASE-LX SFP Module (i) (Model No.:PN54024-TH)</p>	<p>Fiber optic port connector type :LC connector (Duplex)</p> <p>Standards :IEEE802.3z 1000BASE-LX</p> <p>Transmission speed :1000Mbps, full duplex</p> <p>Compatible cable :Fiber cable 10/125 <math>\mu</math> m Single Mode Fiber 50/125 <math>\mu</math> m Multi Mode Fiber 62.5/125 <math>\mu</math> m Multi Mode Fiber</p> <p>Maximum transmission distance :10 km when Single Mode Fiber is used 550 m when Multi Mode Fiber is used</p>

Date issued	Oct. 01, 2019	Panasonic Electric Works Networks Co., Ltd.
Date revised	Apr. 01, 2022	

Model Name	Switch-M8eGi	Product Specification	401-28080i-TH-SP03
Model No.	PN28080i-TH		Page 11 of 13

## 12. Prohibitions when Using the Product to Guarantee Safety

Denotes that “Death or serious injuries might be sustained”.

The manufacturer assumes no responsibility for any problems occurring when the following conditions are not satisfied. Observe the following items when using the product.

- (1) Do not use power supply other than AC 100 - 240 V.  
Deviation could lead to fire, electric shock, and/or equipment failure.
- (2) Do not handle this Ethernet Switch and connection cables during a thunderstorm.  
Deviation could lead to electric shock.
- (3) Do not disassemble and/or modify this Ethernet Switch.  
Deviation could lead to fire, electric shock, and/or equipment failure.
- (4) Do not damage the power cord. Do not bend too tightly, stretch, twist, bundle with other cord, pinch, put under a heavy object and/or heat it.  
Damaged power cord could lead to fire, and/or electric shock.
- (5) Do not handle the power cord with wet hand.  
Deviation could lead to electrical shock, and/or equipment failure.
- (6) Do not insert, nor drop foreign objects such as metal or combustible things into the inside from the openings or twisted pair ports.  
Deviation could lead to fire, electric shock, and/or equipment failure.
- (7) Do not store or use the Ethernet Switch in places where it might get splashed with liquids such as water, in places with a lot of humidity, in places with conductive dust, or in places where there are corrosive and combustible gases.  
Deviation could lead to fire, electrical shock, and/or equipment failure.
- (8) Do not place this Ethernet Switch under direct sunlight and/or high temperature.  
Deviation could lead to high internal temperature and fire.
- (9) Do not install this Ethernet Switch at the location with continuous vibration or strong shock, or at the unstable location.  
Deviation could lead to falling, injury and/or equipment failure.
- (10) Do not put this Ethernet Switch into fire.  
Deviation could lead to explosion and/or fire.
- (11) If the device is going to be used in high temperature environments, do not perform the following operations with bare hands.
  - Relocating the installation area, transporting, and attaching, and removing attachment brackets, etc.
  - Connecting and disconnecting twisted pair cables, fiber optic cables, SFP modules and console cables
  - Attaching, and removing power cords
  - Operating LED display change buttons
 Deviation could lead to injuries or burns, etc. because of high temperatures.
- (12) Do not connect equipments other than 10BASE-T/100BASE-TX/1000BASE-T to twisted pair port.  
When connecting to a 10BASE-T device, use a Cat5 or above cable.  
Deviation could lead to equipment failure.
- (13) Do not insert any other modules into the SFP extension slots (port 9) except for our optional SFP modules (PN54022/PN54024).  
Deviation could lead to equipment failure. Check our website for the latest information on supported SFP modules.
- (14) Do not connect the console ports with any other console cables except for our optional PN72001 RJ45-DSub 9-pin console cable.  
Deviation could lead to fire, electrical shock, and/or equipment failure.

Date issued	Oct. 01, 2019	Panasonic Electric Works Networks Co., Ltd.
Date revised	Apr. 01, 2022	

Model Name	Switch-M8eGi	Product Specification	401-28080i-TH-SP03
Model No.	PN28080i-TH		Page 12 of 13

### 13. Cautions when Using the Product to Guarantee Safety

Denotes that “Minor injuries might be sustained, or property damage might occur”.

The manufacturer assumes no responsibility for any problems occurring when the following conditions are not satisfied. Observe the following items when using the product.

- (1) Use the bundled power cord (AC 100 - 240 V specifications).  
Deviation could lead to electric shock, malfunction, and/or equipment failure.
- (2) Unplug the power cord in case of equipment failure.  
Deviation, such as keeping connected for a long time, could lead to fire.
- (3) Be sure to connect the ground cable.  
Otherwise this might cause electrical shocks, misoperations and malfunctions.  
Connect the Ethernet Switch via the supplied power cord to the outlet which is connected to the ground.  
If the outlet is not connected to a ground, connect the ground cable (AWG18:green/yellow) to the ground terminal screw.
- (4) Connect the power cord firmly to the power port.  
Deviation could lead to electric fire, shock, and/or malfunction.
- (5) If the STATUS (Status) LED blinks orange, unplug the power cord since this is a malfunction.  
Deviation, such as keeping connected for a long time, could lead to fire.
- (6) Handle the Ethernet Switch carefully so that fingers or hands may not be damaged by twisted pair port, SFP extension slot, console port, or power cord hook block.
- (7) Up to two Ethernet Switches can be connected by using the connection brackets and connection bracket screws.  
Attach the connection brackets to the connection bracket screw holes on the front and back panels to securely fix the Ethernet Switches before installation.  
If the Ethernet Switches are not fixed securely, they may fall, leading to injury and/or equipment failure.
- (8) Check whether the optical fiber cable connectors are contaminated with dust, etc.  
This might cause the optical signal to not be transmitted normally, and cause misoperations and malfunctions.  
If they are contaminated, make sure to clean them off, then connect them to the optical fiber ports.
- (9) This Ethernet Switch is to be periodically serviced in order to maintain its performance.  
Please choose a product administrator, and have them be sure to implement periodic maintenance. When doing maintenance, check the inspection chart that is posted on our website which has the requisite items listed on it.
- (10) When using this Ethernet Switch to design systems, use it after applying appropriate measures such as setting up redundant configurations.  
Communications failures might be generated due to causes such as malfunctions or misoperations while the Ethernet Switch is being used.
- (11) When using this Ethernet Switch for applications which require extremely high reliability, be careful to expend all possible means to ensure safety and reliability.  
This Ethernet Switch was not designed nor manufactured with the intention that it be used for applications (in use with railways, aviation, and medical care, etc. whereas the influence rate due to communications failures is extremely high in regard to systems that directly affect systems and human lives) which require extremely high reliability.
- (12) Be aware of glitches which are caused in the usage environments such as age-related degradation, etc.  
This may vary depending upon conditions such as utilisation rates and usage environments, but performance might decrease due to the age-related degradation, etc. of components. It is recommended that this Ethernet Switch be replaced about five years after it has been installed.
- (13) Be careful in regards to environmental restrictions whereby the Ethernet Switch can be used.  
Please isolate the business power lines and communications lines. Isolate distribution lines and other distribution lines, and low current power lines, optical fiber cables, metallic water conduits, and gas conduits, etc. Noise may be generated in the communications lines which might cause communications glitches.

Date issued	Oct. 01, 2019	Panasonic Electric Works Networks Co., Ltd.
Date revised	Apr. 01, 2022	

Model Name	Switch-M8eGi	Product Specification	401-28080i-TH-SP03
Model No.	PN28080i-TH		Page 13 of 13

### 13. Cautions when Using the Product to Guarantee Safety

- (14) Be careful when performing the following operations since the device will be at high temperatures immediately after it has been energized or the power has been shut off.
- Relocating the installation area, transporting, and attaching, and removing attachment brackets, etc.
  - Connecting and disconnecting twisted pair cables, fiber optic cables, SFP modules and console cables
  - Attaching, and removing power cords
  - Operating LED display change buttons
- Deviation could lead to injuries or burns, etc. because of high temperatures.

### 14. Basic Instructions for the Use of This Product

- (1) For inspection and/or diagnosis, consult the shop.
- (2) Use commercial power supply from a wall socket, which is close and easily accessible to this Ethernet Switch.
- (3) Unplug the power cord when installing or moving this Ethernet Switch.
- (4) Unplug the power cord when cleaning this Ethernet Switch.
- (5) Use this Ethernet Switch within the specifications. Deviation could lead to malfunction.
- (6) Do not touch the twisted pair cable modular metal terminals which are connected to RJ45 connectors (twisted pair ports) or the connectors, nor place them near electrically-charged objects. Static electricity could lead to equipment failure.
- (7) Do not put the modular plug of the connected twisted pair cable on objects that can carry static charge, such as carpet. Do not place it in the proximity. Static electricity could lead to equipment failure.
- (8) Do not put a strong shock, including dropping, to this Ethernet Switch. Deviation could lead to equipment failure.
- (9) Before connecting a console cable to the console port, discharge static electricity, for example by touching metal appliance (do not discharge by touching this Ethernet Switch).
- (10) Do not store and/or use this Ethernet Switch in the environment with the characteristics listed below.  
(Store and/or use this Ethernet Switch in the environment in accordance with the specification.)
- High humidity. Possible spilled liquid (water).
  - Dusty. Possible static charge (such as carpet).
  - Under direct sunlight.
  - Possible condensation. High/low temperature exceeding the specifications environment.
  - Strong vibration and/or strong shock.
- (11) Please use this Ethernet Switch in place where ambient temperature is from 0 to 60°C.  
Failure to satisfy the conditions above may result in a fire, electric shock, equipment failure, and/or malfunction. Such events are not covered by the warranty.
- (12) Do not block the ventilator of the Ethernet Switch. Blocked ventilator induces the heat accumulation inside, causing equipment failure and/or malfunction.
- (13) If any module other than the optional SFP extension modules(PN54022/PN54024) is inserted into the SFP extension slot, operation is not guaranteed. For the latest information about compatible SFP extension modules, check our website.
- (14) When using two Ethernet Switches, do not stack them. When you place them side by side, allow for a space of 20 mm or more between them.

Date issued	Oct. 01, 2019	Panasonic Electric Works Networks Co., Ltd.
Date revised	Apr. 01, 2022	