

Model Name	ZEQUO 4600RE	Product Specification	401-36241L-NZ-SP01
Model No.	PN36241L-NZ		Page 1 of 13
<p>1. Summary</p> <p>ZEQUO 4600RE is a Layer 3 Ethernet Switch with management function having 10BASE-T/100BASE-TX/1000BASE-T ports, SFP extension slots, and SFP+ extension slots.</p> <p>2. Feature</p> <p>(1) Has wire-speed Layer 3 switching function.</p> <p>(2) Ports 1 to 24 are 10BASE-T/100BASE-TX/1000BASE-T ports corresponding to auto negotiation. Also their speed and communication mode can be switched by configuration.</p> <p>(3) Ports 21 to 24 are SFP extension slots. These ports and the 1000BASE-T twisted pair cable ports cannot be used simultaneously.</p> <p>(4) Ports 25 to 28 are SFP+ extension slots. They are capable of 10Gbps communications. They can be used as SFP or SFP+ ports.</p> <p>(5) Ports 29 and 30 are stacking ports. Up to four units can be stacked by connecting the ports with optical fiber cable or 40G direct attach cable.</p> <p>(6) Settings and firmware can be changed and saved by using an SD card.</p> <p>(7) Equipped with two power ports, power redundancy is feasible. Normally operates even with just the AC power supplied to either one of the power ports.</p> <p>(8) All twisted pair ports support straight/cross cable by auto sensing function. Simply connect devices with straight cables, whether it is a terminal or a network device.</p> <p>(9) Equipped with energy efficient Ethernet (EEE) conforming to IEEE802.3az (LPI). When there is no data transmission at link up, the energy-saving state automatically starts so that power consumption can be reduced on each port.</p> <p>(10) Power saving mode detects the connection status automatically and saves power consumption to minimum.</p> <p>(11) Due to the loop detection/shutoff function, a port where loop has occurred can be automatically shut off to prevent loop failures.</p> <p>(12) The ports which the loop has generated are displayed via the LED, and the network administrator can specify the ports which the loop has generated after the loop is resolved via the loop history functions.</p> <p>(13) The Ring Redundant Protocol (RRP) is supported, allowing to make a redundant network via ring topology.</p> <p>(14) Supports ZEQUO assist Plus. Processes from introduction to maintenance can be performed easily.</p>			
Date issued	Oct. 21 ,2022	Panasonic Electric Works Networks Co.,Ltd.	
Date revised			

Model Name	ZEQUO 4600RE	Product Specification	401-36241L-NZ-SP01
Model No.	PN36241L-NZ		Page 2 of 13

3. Rated/Environmental Conditions

3-1. Power supply	AC100-240V, 50/60Hz, 2.5A (with a built-in power supply)
3-2. Power consumption	When either power port 1, or power port 2 is connected Normally, Max. 46.8 W, Min. 30.8 W When both power port 1 and power port 2 are connected Normally, Max. 51.2 W, Min. 34.8 W *Power redundancy is feasible
3-3. Operating environment	Temperature: 0 - 45°C Humidity: 20 - 80%RH (no condensation)
3-4. Storage environment	Temperature: -20 - 70°C Humidity: 10 - 90%RH (no condensation)
3-5. EMC compliance	CISPR 32 Class A EN 55032 Class A AS/NZS CISPR32 Class A VCCI Class A EN 61000-3-2, EN 61000-3-3 CISPR 24 EN 55024 IEC 61000-4-2, IEC 61000-4-3, IEC 61000-4-4, IEC 61000-4-5, IEC 61000-4-6, IEC 61000-4-8, IEC 61000-4-11
3-6. Safety compliance	IEC 62368-1 EN 62368-1
3-7. Environment compliance	RoHS compliant

4. Form

4-1. Form and materials/colors	Dimensions : 44mm (Height) × 440mm (Width) × 312mm (Depth) (Excluding protruding sections) Case material : Main unit: SECC, Front face: PC/ABS, Face plate: PC Color : Main unit: Green 03, Front face: Silver 01, Face plate label: Black 01
4-2. Mass (Weight)	5,000g (When either power port 1, or power port 2 is connected) 5,600g (When both power port 1 and power port 2 are connected)

Date issued	Oct. 21 ,2022	Panasonic Electric Works Networks Co.,Ltd.
Date revised		

Model Name	ZEQUO 4600RE	Product Specification	401-36241L-NZ-SP01
Model No.	PN36241L-NZ		Page 3 of 13

5. Hardware Specifications

5-1. Interface	<p>Twisted pair port 1-24 :RJ45 connector Transmitting and receiving network system: IEEE802.3 10BASE-T IEEE802.3u 100BASE-TX IEEE802.3ab 1000BASE-T</p> <p>Transmission speed :10/100/1000Mbps, full/half duplex Compatible cable :Twisted pair cable (At least equivalent to EIA/TIA568 category 5e)</p> <p>Maximum transmission distance :100m Auto-Negotiation :Communication speed and full/half duplex are automatically recognized. The setting can be fixed to 10Mbps, 100Mbps, or 1000Mbps and full duplex or half duplex.</p> <p>Power saving mode : Detects the connection status automatically and saves power consumption to minimum.</p> <p>SFP extension slot 21-24 SFF-8472 (DMI:Diagnostic Monitoring Interface) *Select either of RJ45 or SFP for use (Port21-24) Optional Accessories : 1000BASE-SX SFP Module (PN54021K-NZ) 1000BASE-LX SFP Module (PN54023K-NZ)</p> <p>SFP+ extension slot 25-28 SFF-8472 (DMI:Diagnostic Monitoring Interface) *Select either of RJ45 or SFP for use Optional Accessories : 1000BASE-SX SFP Module (PN54021K-NZ) 1000BASE-LX SFP Module (PN54023K-NZ) 10GBASE-SR SFP+ Module (PN59021-NZ) 10GBASE-LR SFP+ Module (PN59023-NZ)</p> <p>Stack port 29-30 Optional Accessories : 40G direct attach cables 1m</p> <p>FAN Module slot 2slots Supported FAN Module model: FAN01 Module (PN73002) Hot swap: Supported</p> <p>PSU Module slot 2slots Supported PSU Module model: RP02-200W Module (70002-NZ) Hot swap: Supported</p>
5-2. Switching mode	<p>Switching method :Store and Forward Switching capacity :288Gbps Packet transfer capability :Non-blocking Max 14,880,000pps/port (10Gbps) Max 1,488,000pps/port (1000Mbps) Max 148,800pps/port (100Mbps) Max 14,880pps/port (10Mbps)</p> <p>MAC Address table :Max 96K entry/unit Buffer memory :4M Byte/unit Flow control :half-duplex Back pressure full-duplex IEEE802.3x</p> <p>Aging timeout :10 to 1,000,000 sec. (Default: 300 sec.) Jumbo frame :13KB</p>

Date issued	Oct. 21 ,2022	Panasonic Electric Works Networks Co.,Ltd.
Date revised		

Model Name	ZEQUO 4600RE	Product Specification	401-36241L-NZ-SP01
Model No.	PN36241L-NZ		Page 4 of 13

5. Hardware Specifications

5-3. Terminal emulator connection	Console port :RJ45 connector 1 port Transmission mode :RS-232C (ITU-TS V.24) Emulation mode :VT100 Communication configuration :9,600bps, 8bit, None Parity control, Stop bit 1 bit
5-4. Stack	Number of units :Four units max. Bandwidth :80Gbps max. Stack topology :Chain, Ring
5-5. SD card slot	SD card slot :1slot Standard :SD/SDHC Size :128MByte to 32GByte
5-6. LED display	<p>(1) POWER1 LED Green Light : Power is ON. Off : Power is OFF or Internal power supply error.</p> <p>(2) POWER2 LED Green Light : Power is ON. Off : Power is OFF or Internal power supply error.</p> <p>(3) STATUS LED Green Light : The system is normally operating. Orange Light : Starting Orange Blink : Malfunction (Contact the seller.) Off : Power is OFF.</p> <p>(4) SD CARD LED Green Light : SD card inserted Green Blink : Reading/writing data Orange Blink : SD card error Off : No SD card</p> <p>(5) STACK ID LED Indicating "H" and the STACK ID alternately : Master switch Indicating "h" and the STACK ID alternately : Backup master switch Indicating the STACK ID : Slave switch</p> <p>*In case the STATUS LED blinks in orange, the following is also indicated. "P" : Power failure "11" : Fan1 failure "12" : Fan2 failure "13" : Fan1 or Fan2 failure "L" : Within 3 days after a loop resolution</p> <p>(6) Port LED LINK/ACT. (Port 1-24) Green Light : Link is established at 10/100/1000 Mbps. Green Blink : Transmitting and receiving data at 10/100/1000 Mbps. Orange Light : Shuts off due to loop detection and shutoff functions/ storm controls/BPDU guard Orange Blink : Transmitting and receiving just the administration packets Off : No devices are connected.</p> <p>LINK/ACT. (Port 21-24) Green Light : Link is established at 1000 Mbps. Green Blink : Transmitting and receiving data at 1000 Mbps. Orange Light : Shuts off due to loop detection and shutoff functions/ storm controls/BPDU guard Orange Blink : Transmitting and receiving just the administration packets Off : No devices are connected.</p>

Date issued	Oct. 21 ,2022	Panasonic Electric Works Networks Co.,Ltd.
Date revised		

Model Name	ZEQUO 4600RE	Product Specification	401-36241L-NZ-SP01
Model No.	PN36241L-NZ		Page 5 of 13

5. Hardware Specifications

5-6. LED display	<p>LINK/ACT (SFP+ port 25-28)</p> <p>Green Light : Link is established at 1000 Mbps or 10 Gbps. Green Blink : Transmitting and receiving data at 1000 Mbps or 10 Gbps. Orange Light : Shuts off due to loop detection and shutoff functions/storm controls/BPDU guard Orange Blink : Transmitting and receiving just the administration packets Off : No devices are connected.</p> <p>LINK/ACT (STACK port 29-30)</p> <p>Green Light : Link is established at 40 Gbps. Green Blink : Transmitting and receiving data at 40 Gbps. Orange Light : Shuts off due to loop detection and shutoff functions/storm controls/BPDU guard Orange Blink: Transmitting and receiving just the administration packets Off : No devices are connected.</p>
5-7. Cascade connections	<p>Port 1-24 corresponding to the Auto MDI / MDI-X. The ports set as fixed are MDI-X. Port 21-24 are set to Auto MDI / MDI-X (factory default).</p>
5-8. FAN	Installed

6. Software Specifications

6-1. Configuration	<p>Control parameters can be set by the following procedures:</p> <p>(1) Configuration from an asynchronous terminal connected to the console port. (2) Configuration from a remote terminal connected via TELNET and SSH.</p>																		
6-2. Ethernet Switch Control	<p>It is possible to check the control and operation of the Ethernet Switch by ZEQUO assist Plus.</p> <p>Ethernet Switch can be controlled by the following procedures:</p> <p>(1) Control from an asynchronous terminal connected to the console port. (2) Control from a remote terminal using SSH/TELNET and TCP/IP network connection. (3) Control using SNMP Manager</p> <p>The Ethernet Switch operation status can be checked using the following functions.</p> <p>(1) Fan sensor function (2) Internal temperature sensor function (3) Function to display the CPU usage and memory usage (4) SFP module status checking function (DDM: Digital Diagnostic Monitoring)</p>																		
6-3. Rebooting	<p>The system can be reboot from the software in the following two modes:</p> <p>(1) Warm start (2) Reset to factory default</p>																		
6-4. Supported Agent	<table> <tr> <td>Management protocol</td> <td>:SNMP v1/v2c/v3</td> <td>(RFC1157, RFC1901, RFC 1908, RFC 2570, RFC 2575)</td> </tr> <tr> <td></td> <td>TELNET</td> <td>(RFC854)</td> </tr> <tr> <td></td> <td>SSH v2</td> <td>(RFC4250,RFC4251, RFC4252, RFC4253,RFC4254)</td> </tr> <tr> <td>Management protocol</td> <td>:PPSP</td> <td></td> </tr> <tr> <td></td> <td>Easy IP Setup Protocol</td> <td></td> </tr> <tr> <td>Data transfer protocol</td> <td>:TFTP</td> <td>(RFC783)</td> </tr> </table>	Management protocol	:SNMP v1/v2c/v3	(RFC1157, RFC1901, RFC 1908, RFC 2570, RFC 2575)		TELNET	(RFC854)		SSH v2	(RFC4250,RFC4251, RFC4252, RFC4253,RFC4254)	Management protocol	:PPSP			Easy IP Setup Protocol		Data transfer protocol	:TFTP	(RFC783)
Management protocol	:SNMP v1/v2c/v3	(RFC1157, RFC1901, RFC 1908, RFC 2570, RFC 2575)																	
	TELNET	(RFC854)																	
	SSH v2	(RFC4250,RFC4251, RFC4252, RFC4253,RFC4254)																	
Management protocol	:PPSP																		
	Easy IP Setup Protocol																		
Data transfer protocol	:TFTP	(RFC783)																	

Date issued	Oct. 21 ,2022	Panasonic Electric Works Networks Co.,Ltd.
Date revised		

Model Name	ZEQUO 4600RE	Product Specification	401-36241L-NZ-SP01
Model No.	PN36241L-NZ		Page 6 of 13

6. Software Specifications

6-5. Supported MIB	RFC1213-MIB (MIB II) (RFC 1213) BRIDGE- MIB (RFC 4188) SNMPv2-MIB (RFC 1907) RMON-MIB (RFC 2819) RMON2-MIB (RFC 2021) EtherLike-MIB (RFC 2665) MAU-MIB (RFC 4836) P-BRIDGE- MIB (RFC 4363) IF-MIB (RFC 2863) RADIUS-AUTH-CLIENT-MIB (RFC 2618) MGMD-STD- MIB (RFC 5519) RIPv2-MIB (RFC 1724) IP-FORWARD-MIB (RFC 4292) RADIUS-ACC-CLIENT-MIB (RFC 2620) DISMAN-PING-MIB (RFC 2925) DISMAN-TRACEROUTE-MIB (RFC 2925) VRRP-MIB (RFC 2787) ENTITY-MIB (RFC 2737) IPV6-MIB (RFC 4293)
6-6. System log	Maximum number to be kept:10,000 System log transfer (IPv4/IPv6)
6-7. Loop detection	Turns on the port LED with a orange light when a loop occurs in the corresponding port. At this time, the relevant port automatically shuts down to prevent loop from occurring. SNMP trap can be sent to notify the incident to the administrator. During loop is occurring, or if loop has occurred within the latest 3 days, STATUS LED green blinks to notify this. <ul style="list-style-type: none"> · Loop detection port <ul style="list-style-type: none"> Enabled: Ports 1 to 24 (factory default setting) Disabled: Ports 25 and 30 (factory default setting) · Loop detection setting <ul style="list-style-type: none"> Enabled (factory default setting) Enabled/disabled can be switched by configuring a setting using the console · Loop shutoff time <ul style="list-style-type: none"> 60 to 86400 sec. (Factory default setting: 60 sec.) The set time Port LED lights up orange and the port shuts off. · Loop shut off mode <ul style="list-style-type: none"> shutdown mode Blocking mode (factory default setting)
6-8. Others	Syslog Client (Transfers system logs to the Syslog server.) TFTP Client (Upgrades the software and saves/loads configuration information.) TELNET Client DHCP Client SNTP LLDP LLDP-MED DNS relay DNS Resolver DHCP Snooping

Date issued	Oct. 21 ,2022	Panasonic Electric Works Networks Co.,Ltd.
Date revised		

Model Name	ZEQUO 4600RE	Product Specification	401-36241L-NZ-SP01
Model No.	PN36241L-NZ		Page 7 of 13

7. Layer 2 Switching Functions

7-1. Spanning Tree	IEEE 802.1D Spanning Tree Protocol, Rapid Spanning Tree Protocol IEEE 802.1Q Multiple Spanning Tree Protocol
7-2. VLAN	IEEE802.1Q Private VLAN Guest VLAN MAC-based VLAN Subnet based VLAN Number of VLAN registrations: 4,094 (including default) Asymmetric VLAN Voice VLAN
7-3. Trunking	Link Aggregation function (LACP/Manual) Up to 48 groups can be created (up to 8 ports per group).
7-4. Port Monitoring	Traffic of the target port can be copied to the specified port and transmitted. (Two or more target ports can be specified.) RSPAN
7-5. Multicast	IGMP Snooping (IGMP v1/v2/v3) function (Maximum group number :4,096, Number of Static registrations:128) MLD snooping (MLDv2) function (Maximum group number :2,048, Number of Static registrations:128)
7-6. QoS	IEEE802.1p 8 levels of Priority Queue supported Scheduling Method: Strict Priority Queuing (SPQ:Strict priority queuing scheduling) Weighted Round Robin (WRR:Weighted round robin scheduling) Weighted Deficit Round Robin (WDRR: Weighted Deficit Round Robin scheduling)
7-7. Authentication Function	Web-based authentication IEEE802.1X Port-based authentication Web-based authentication, Mac-based authentication using IEEE 802.1X Web-based authentication, Dynamic VLAN function using IEEE 802.1X Guest VLAN using IEEE 802.1X (EAP-MD5/TLS/PEAP authentication method)
7-8. Fan control	Automatic adjustment of fan rotation speed according to usage environment
7-9. Access Control	Access control can be controlled by the following parameters: (1) IP address (Source or Destination) (2) MAC address (Source or Destination) (3) TCP/UDP port number (Source or Destination) (4) VLAN ID (5) IEEE 802.1p Priority (6) DSCP (7) Protocol (8) ICMP type (9) TCP SYN Flag
7-10. Ring protocol	Redundancy is enabled by ring topology. (Up to 8 group can be registered.)

Date issued	Oct. 21 ,2022	Panasonic Electric Works Networks Co.,Ltd.
Date revised		

Model Name	ZEQUO 4600RE	Product Specification	401-36241L-NZ-SP01
Model No.	PN36241L-NZ		Page 8 of 13

8. Layer 3 Switching Functions

8-1. IP interface	IP interface Multiple IP addresses	:256 max. :256 / Interface
8-2. IPv4 routing	Static RIP v1/v2	
8-3. IPv6 routing	Static	
8-4. Routing table	Static Dynamic	:256 (IPv4) ,128 (IPv6) :12K (IPv4)
8-5. IP forwarding	95 M bps max.	
8-6. VRRP	Maximum number of virtual router	:256
8-8. DHCPv4 server	Allocatable IP address Max. pool Max. manual binding address	:1,024/pool :10 :16
8-9. DHCPv6 server	Allocatable IP address Max. pool Max. manual binding address	:4,096 (shared by all pools) :16 :64
8-10. DHCP relay	DHCP Option DHCP v6 Option Supported local relay	:60, 61, 82 :18,37

Date issued	Oct. 21 ,2022	Panasonic Electric Works Networks Co.,Ltd.
Date revised		

Model Name	ZEQUO 4600RE	Product Specification	401-36241L-NZ-SP01
Model No.	PN36241L-NZ		Page 9 of 13

9. Web management function

9-1. Software specification																									
9-1-1. Enabled browser	Microsoft Internet Explorer 11																								
9-2. Setting function																									
9-2-1. Switching configuration	<table border="0"> <tr> <td>Administration</td> <td>Static multicast address</td> </tr> <tr> <td>IP</td> <td>System log</td> </tr> <tr> <td>Port (basic, extend, Power saving)</td> <td>Exception handler</td> </tr> <tr> <td>Access condition</td> <td>Watchdog timer</td> </tr> <tr> <td>Syslog transmission</td> <td>RIP</td> </tr> <tr> <td>ID/Password</td> <td>Stack</td> </tr> <tr> <td>Static ARP table</td> <td>IGMP snooping</td> </tr> <tr> <td>VLAN settings</td> <td></td> </tr> <tr> <td>QoS settings</td> <td></td> </tr> <tr> <td>Link aggregation</td> <td></td> </tr> <tr> <td>Storm control</td> <td></td> </tr> <tr> <td>Port monitoring</td> <td></td> </tr> </table>	Administration	Static multicast address	IP	System log	Port (basic, extend, Power saving)	Exception handler	Access condition	Watchdog timer	Syslog transmission	RIP	ID/Password	Stack	Static ARP table	IGMP snooping	VLAN settings		QoS settings		Link aggregation		Storm control		Port monitoring	
Administration	Static multicast address																								
IP	System log																								
Port (basic, extend, Power saving)	Exception handler																								
Access condition	Watchdog timer																								
Syslog transmission	RIP																								
ID/Password	Stack																								
Static ARP table	IGMP snooping																								
VLAN settings																									
QoS settings																									
Link aggregation																									
Storm control																									
Port monitoring																									
9-2-2. Time setting	SNTP setting, manual setting																								
9-3. Monitoring function																									
9-3-1. Basic information	System information, Hardware information, Management information [Host name (sysName), System address information]																								
9-3-2. Learning and recording information	FDB table, ARP table, Statistics information, System log																								
9-4. System management tools	Software upgrade, Reboot, Save current, Config file transfer, Ping execution																								
9-5. Routing setting	OSPF, RIP, Static routing, Policy-based routing, Multicast routing protocol																								

10. Connector Pin Arrangement

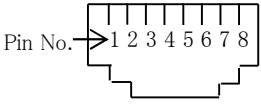
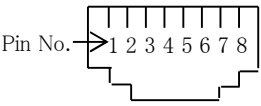
10-1. Port 21 - 24																															
<table border="1"> <thead> <tr> <th>Status</th> <th>Pin No.</th> <th>1</th> <th>2</th> <th>3</th> <th>6</th> <th>4</th> <th>5</th> <th>7</th> <th>8</th> </tr> </thead> <tbody> <tr> <td>MDI-X</td> <td>Signal</td> <td>BL_DB+</td> <td>BL_DB-</td> <td>BL_DA+</td> <td>BL_DA-</td> <td>BL_DD+</td> <td>BL_DD-</td> <td>BL_DC+</td> <td>BL_DC-</td> </tr> <tr> <td>MDI</td> <td>Signal</td> <td>BL_DA+</td> <td>BL_DA-</td> <td>BL_DB+</td> <td>BL_DB-</td> <td>BL_DC+</td> <td>BL_DC-</td> <td>BL_DD+</td> <td>BL_DD-</td> </tr> </tbody> </table>	Status		Pin No.	1	2	3	6	4	5	7	8	MDI-X	Signal	BL_DB+	BL_DB-	BL_DA+	BL_DA-	BL_DD+	BL_DD-	BL_DC+	BL_DC-	MDI	Signal	BL_DA+	BL_DA-	BL_DB+	BL_DB-	BL_DC+	BL_DC-	BL_DD+	BL_DD-
Status	Pin No.	1	2	3	6	4	5	7	8																						
MDI-X	Signal	BL_DB+	BL_DB-	BL_DA+	BL_DA-	BL_DD+	BL_DD-	BL_DC+	BL_DC-																						
MDI	Signal	BL_DA+	BL_DA-	BL_DB+	BL_DB-	BL_DC+	BL_DC-	BL_DD+	BL_DD-																						
10-2. Console port																															
<table border="1"> <thead> <tr> <th>Pin No.</th> <th>Signal</th> <th>Pin No.</th> <th>Signal</th> </tr> </thead> <tbody> <tr> <td>1</td> <td>NC</td> <td>5</td> <td>GND</td> </tr> <tr> <td>2</td> <td>NC</td> <td>6</td> <td>RXD</td> </tr> <tr> <td>3</td> <td>TXD</td> <td>7</td> <td>NC</td> </tr> <tr> <td>4</td> <td>GND</td> <td>8</td> <td>NC</td> </tr> </tbody> </table>	Pin No.		Signal	Pin No.	Signal	1	NC	5	GND	2	NC	6	RXD	3	TXD	7	NC	4	GND	8	NC										
Pin No.	Signal	Pin No.	Signal																												
1	NC	5	GND																												
2	NC	6	RXD																												
3	TXD	7	NC																												
4	GND	8	NC																												

Date issued	Oct. 21 ,2022	Panasonic Electric Works Networks Co.,Ltd.
Date revised		

Model Name	ZEQUO 4600RE	Product Specification	401-36241L-NZ-SP01
Model No.	PN36241L-NZ		Page 10 of 13

11. Installation Procedures and Accessories

11-1. Installation Procedures	Mounting to rack																						
11-2. Accessories	<table border="0"> <tr><td>(1) Installation Guide</td><td>:1</td></tr> <tr><td>(2) Rubber foot</td><td>:4</td></tr> <tr><td>(3) Mounting bracket (for 19-inch rack)</td><td>:2</td></tr> <tr><td>(4) Screw (for 19-inch rack)</td><td>:4</td></tr> <tr><td>(5) Power module (70002-NZ RP02-200W Module)</td><td>:1 (unit mounted)</td></tr> <tr><td>(6) Power module blank panel</td><td>:1 (unit mounted)</td></tr> <tr><td>(7) Fan module (PN73002 FAN02 Module)</td><td>:2 (unit mounted)</td></tr> <tr><td>(8) Screw (for fixing the main unit and the mounting bracket)</td><td>:8</td></tr> <tr><td>(9) 40G Direct attach cable</td><td>:1</td></tr> <tr><td>(10) Dummy SD card</td><td>:1 (unit mounted)</td></tr> <tr><td>(11) Power cord (AS/NZS3112)(*)</td><td>:1</td></tr> </table> <p>* The attached power cord is dedicated for AC 100 - 240 V use.</p>	(1) Installation Guide	:1	(2) Rubber foot	:4	(3) Mounting bracket (for 19-inch rack)	:2	(4) Screw (for 19-inch rack)	:4	(5) Power module (70002-NZ RP02-200W Module)	:1 (unit mounted)	(6) Power module blank panel	:1 (unit mounted)	(7) Fan module (PN73002 FAN02 Module)	:2 (unit mounted)	(8) Screw (for fixing the main unit and the mounting bracket)	:8	(9) 40G Direct attach cable	:1	(10) Dummy SD card	:1 (unit mounted)	(11) Power cord (AS/NZS3112)(*)	:1
(1) Installation Guide	:1																						
(2) Rubber foot	:4																						
(3) Mounting bracket (for 19-inch rack)	:2																						
(4) Screw (for 19-inch rack)	:4																						
(5) Power module (70002-NZ RP02-200W Module)	:1 (unit mounted)																						
(6) Power module blank panel	:1 (unit mounted)																						
(7) Fan module (PN73002 FAN02 Module)	:2 (unit mounted)																						
(8) Screw (for fixing the main unit and the mounting bracket)	:8																						
(9) 40G Direct attach cable	:1																						
(10) Dummy SD card	:1 (unit mounted)																						
(11) Power cord (AS/NZS3112)(*)	:1																						

12. Optional accessories

12-1. 1000BASE-SX SFP Module (Model No. :PN54021K-NZ)	<table border="0"> <tr><td>Fiber optic port connector type</td><td>:LC connector (Duplex)</td></tr> <tr><td>Standards</td><td>:IEEE802.3z 1000BASE-SX</td></tr> <tr><td>Transmission speed</td><td>: 1000Mbps, full duplex</td></tr> <tr><td>Compatible cable</td><td>:Fiber cable 50/125 μ m Multi Mode Fiber 62.5/125 μ m Multi Mode Fiber</td></tr> <tr><td>Maximum transmission distance</td><td>:550 m at 50/125 μ m 220 m at 62.5/125 μ m</td></tr> </table>	Fiber optic port connector type	:LC connector (Duplex)	Standards	:IEEE802.3z 1000BASE-SX	Transmission speed	: 1000Mbps, full duplex	Compatible cable	:Fiber cable 50/125 μ m Multi Mode Fiber 62.5/125 μ m Multi Mode Fiber	Maximum transmission distance	:550 m at 50/125 μ m 220 m at 62.5/125 μ m
Fiber optic port connector type	:LC connector (Duplex)										
Standards	:IEEE802.3z 1000BASE-SX										
Transmission speed	: 1000Mbps, full duplex										
Compatible cable	:Fiber cable 50/125 μ m Multi Mode Fiber 62.5/125 μ m Multi Mode Fiber										
Maximum transmission distance	:550 m at 50/125 μ m 220 m at 62.5/125 μ m										
12-2. 1000BASE-LX SFP Module (Model No. :PN54023K-NZ)	<table border="0"> <tr><td>Fiber optic port connector type</td><td>:LC connector (Duplex)</td></tr> <tr><td>Standards</td><td>:IEEE802.3z 1000BASE-LX</td></tr> <tr><td>Transmission speed</td><td>: 1000Mbps, full duplex</td></tr> <tr><td>Compatible cable</td><td>:Fiber cable 10/125 μ m Single Mode Fiber 50/125 μ m Multi Mode Fiber 62.5/125 μ m Multi Mode Fiber</td></tr> <tr><td>Maximum transmission distance</td><td>:10 km when Single Mode Fiber is used 550 m when Multi Mode Fiber is used</td></tr> </table>	Fiber optic port connector type	:LC connector (Duplex)	Standards	:IEEE802.3z 1000BASE-LX	Transmission speed	: 1000Mbps, full duplex	Compatible cable	:Fiber cable 10/125 μ m Single Mode Fiber 50/125 μ m Multi Mode Fiber 62.5/125 μ m Multi Mode Fiber	Maximum transmission distance	:10 km when Single Mode Fiber is used 550 m when Multi Mode Fiber is used
Fiber optic port connector type	:LC connector (Duplex)										
Standards	:IEEE802.3z 1000BASE-LX										
Transmission speed	: 1000Mbps, full duplex										
Compatible cable	:Fiber cable 10/125 μ m Single Mode Fiber 50/125 μ m Multi Mode Fiber 62.5/125 μ m Multi Mode Fiber										
Maximum transmission distance	:10 km when Single Mode Fiber is used 550 m when Multi Mode Fiber is used										
12-3. 10GBASE-SR SFP+ Module (Model No. :PN59021-NZ)	<table border="0"> <tr><td>Fiber optic port connector type</td><td>:LC connector (Duplex)</td></tr> <tr><td>Standards</td><td>:IEEE802.3ae 10GBASE-SR</td></tr> <tr><td>Transmission speed</td><td>:10Gbps full duplex</td></tr> <tr><td>Compatible cable</td><td>:Fiber cable 50/125 μ m Multi Mode Fiber 62.5/125 μ m Multi Mode Fiber</td></tr> <tr><td>Maximum transmission distance</td><td>:300 m at 50/125 μ m 33 m at 62.5/125 μ m</td></tr> </table>	Fiber optic port connector type	:LC connector (Duplex)	Standards	:IEEE802.3ae 10GBASE-SR	Transmission speed	:10Gbps full duplex	Compatible cable	:Fiber cable 50/125 μ m Multi Mode Fiber 62.5/125 μ m Multi Mode Fiber	Maximum transmission distance	:300 m at 50/125 μ m 33 m at 62.5/125 μ m
Fiber optic port connector type	:LC connector (Duplex)										
Standards	:IEEE802.3ae 10GBASE-SR										
Transmission speed	:10Gbps full duplex										
Compatible cable	:Fiber cable 50/125 μ m Multi Mode Fiber 62.5/125 μ m Multi Mode Fiber										
Maximum transmission distance	:300 m at 50/125 μ m 33 m at 62.5/125 μ m										
12-4. 10GBASE-LR SFP+ Module (Model No. :PN59023-NZ)	<table border="0"> <tr><td>Fiber optic port connector type</td><td>:LC connector (Duplex)</td></tr> <tr><td>Standards</td><td>:IEEE802.3ae 10GBASE-LR</td></tr> <tr><td>Transmission speed</td><td>:10Gbps full duplex</td></tr> <tr><td>Compatible cable</td><td>:Fiber cable 10/125 μ m Single Mode Fiber</td></tr> <tr><td>Maximum transmission distance</td><td>:10km</td></tr> </table>	Fiber optic port connector type	:LC connector (Duplex)	Standards	:IEEE802.3ae 10GBASE-LR	Transmission speed	:10Gbps full duplex	Compatible cable	:Fiber cable 10/125 μ m Single Mode Fiber	Maximum transmission distance	:10km
Fiber optic port connector type	:LC connector (Duplex)										
Standards	:IEEE802.3ae 10GBASE-LR										
Transmission speed	:10Gbps full duplex										
Compatible cable	:Fiber cable 10/125 μ m Single Mode Fiber										
Maximum transmission distance	:10km										
12-7. RP02-200W Module (Order Model No. :70002-NZ)	<table border="0"> <tr><td>Power supply module</td><td></td></tr> <tr><td>* This supply module is dedicated for ZEQUO 6700RE/ZEQUO 6600RE/ZEQUO 4600RE use.</td><td></td></tr> </table>	Power supply module		* This supply module is dedicated for ZEQUO 6700RE/ZEQUO 6600RE/ZEQUO 4600RE use.							
Power supply module											
* This supply module is dedicated for ZEQUO 6700RE/ZEQUO 6600RE/ZEQUO 4600RE use.											
12-8. FAN02 Module (Model No. :PN73002)	<table border="0"> <tr><td>FAN module</td><td></td></tr> <tr><td>* This FAN module is dedicated for ZEQUO 6700RE/ZEQUO6600RE/ZEQUO4600RE use.</td><td></td></tr> </table>	FAN module		* This FAN module is dedicated for ZEQUO 6700RE/ZEQUO6600RE/ZEQUO4600RE use.							
FAN module											
* This FAN module is dedicated for ZEQUO 6700RE/ZEQUO6600RE/ZEQUO4600RE use.											

Date issued	Oct. 21 ,2022	Panasonic Electric Works Networks Co.,Ltd.
Date revised		

Model Name	ZEQUO 4600RE	Product Specification	401-36241L-NZ-SP01
Model No.	PN36241L-NZ		Page 11 of 13

13. Prohibitions when Using the Product to Guarantee Safety

Denotes that “Death or serious injuries might be sustained”.

The manufacturer assumes no responsibility for any problems occurring when the following conditions are not satisfied. Observe the following items when using the product.

- (1) Do not use power supply other than AC 100 – 240 V.
Deviation could lead to fire, electric shock, and/or equipment failure.
- (2) Do not handle this Ethernet Switch and connection cables during a thunderstorm.
Deviation could lead to electric shock.
- (3) Do not disassemble and/or modify this Ethernet Switch.
Deviation could lead to fire, electric shock, and/or equipment failure.
- (4) Do not damage the power cord. Do not bend too tightly, stretch, twist, bundle with other cord, pinch, put under a heavy object and/or heat it.
Damaged power cord could lead to fire, short, and/or electric shock.
- (5) Do not unplug nor plug in the power plug with wet hands.
Deviation could lead to electrical shock, and/or equipment failure.
- (6) Do not insert or drop any foreign objects such as metal or readily combustible things into Ethernet Switch through the openings.
Deviation could lead to fire, electrical shock, and/or equipment failure.
- (7) Do not store or use the Ethernet Switch in places where it might get splashed with liquids such as water, in places with a lot of humidity, in places with conductive dust, or in places where there are corrosive and combustible gases.
Deviation could lead to fire, electrical shock, and/or equipment failure.
- (8) Do not use the Ethernet Switch in dusty environments such as on floors, underneath floors, the backside of ceilings, or boards.
Do not use the Ethernet Switch in very dusty areas such as on floors, underneath floors, the backside of ceilings, or boards. Deviation could lead to fire, electrical shock, and/or equipment failure. It is recommended that the Ethernet Switch be operated in environments such as the inside of racks where it is difficult for dust to be generated.
- (9) Do not store or use the Ethernet Switch in places where it will be exposed to direct sunlight or high temperatures.
The temperature inside will rise, which may cause fire.
- (10) Do not store or use the Ethernet Switch in places where there are lots of vibrations and impacts, or in unstable areas.
It might fall, which may cause injuries and/or equipment failure.
- (11) Do not put the Ethernet Switch into fire.
Deviation could lead to explosion and/or fire.
- (12) Do not connect any other devices except for 10BASE-T/100BASE-TX/1000BASE-T devices to the twisted pair ports.
Deviation could lead to equipment failure.
- (13) Do not insert any other modules except for our optional SFP module (PN54021K/PN54023K) and the SFP+ module (PN59021/PN59023) to the SFP+ extension slots.
- (14) Do not insert any other modules except for our optional SFP module (PN54021K/PN54023K), SFP+ module (PN59021/PN59023), or 40G direct attach cable to the stacking ports (Port29-30).
Check out our website for the latest information on supported SFP modules.
- (15) Do not insert nor use any other modules except for our optional FAN02 Module (PN73002) into the fan module slots.
Deviation could lead to electric shock, malfunction, and/or equipment failure.
- (16) Do not insert nor use any other modules except for our optional RP02-200W Module (70002-NZ) into the power module slots.
Deviation could lead to electric shock, malfunction, and/or equipment failure.

Date issued	Oct. 21 ,2022	Panasonic Electric Works Networks Co.,Ltd.
Date revised		

Model Name	ZEQUO 4600RE	Product Specification	401-36241L-NZ-SP01
Model No.	PN36241L-NZ		Page 12 of 13

14. Cautions when Using the Product to Guarantee Safety

- (1) Be sure to check the precautions which are printed on the product labels before using.
Deviation could lead to electric shock.
- (2) Use the bundled power cord (AC 100 - 240 V specifications).
Deviation could lead to electric shock, malfunction, and/or equipment failure.
- (3) Unplug the power cord in case of equipment failure.
Deviation, such as keeping connecting for a long time, could lead to fire.
- (4) Be sure to connect the ground cable.
Otherwise this might cause electrical shocks, misoperations and malfunctions.
Connect the Ethernet Switch via the supplied power cord to the outlet which is connected to the ground.
If the outlet is not connected to a ground, connect the ground cable to the ground terminal screw.
- (5) Connect the power cord firmly to the power port.
Deviation could lead to electric fire, shock, and/or malfunction.
- (6) If the STATUS LED is blinking in orange (system fault), check for the cause via the system log,
since it might be a malfunction if it is not the temperature, loop detection and shutoff, unplug the power plug.
Deviation, such as keeping connecting for a long time, could lead to fire.
- (7) Handle the Ethernet Switch carefully to prevent fingers and hands from being
damaged by twisted pair port, SFP extension slot, Stacking port, console port,
SD card slot, or power cord hook block.
- (8) Check whether the optical fiber cable connectors are contaminated with dust, etc.
This might cause the optical signal to not be transmitted normally, and cause
misoperations and malfunctions. If they are contaminated, make sure to clean
them off, then connect them to the optical fiber ports.
- (9) This Ethernet Switch is to be periodically serviced in order to maintain its performance.
Please assign a product administrator, and be sure to implement periodic maintenance.
When doing maintenance, check the inspection chart that is posted on our website which has the requisite items listed on it.
- (10) When using this Ethernet Switch to design systems, use it after applying
appropriate measures such as setting up redundant configurations.
Communication failures might be generated due to causes such as malfunctions or
misoperations while the Ethernet Switch is being used.
- (11) When using this Ethernet Switch for applications which require extremely high reliability, be careful to expend all possible
means to ensure safety and reliability.
This Ethernet Switch is not designed nor manufactured with the intention that it be
used for applications (in use with railways, aviation, and medical care, etc. whereas
the influence rate due to communications failures is extremely high in regard to
systems that directly affect systems and human lives) which require extremely high
reliability.
- (12) It is recommended that this Ethernet Switch be replaced about five years after it has been installed.
This may vary depending upon conditions such as utilisation rates and usage
environments, but performance might decrease due to the age-related degradation, etc. of components.
- (13) Be careful in regards to environmental restrictions whereby the Ethernet Switch can be used.
Please isolate the business power lines and communications lines. Isolate distribution
lines and other distribution lines, and low current power lines, optical fiber cables,
metallic water conduits, and gas conduits, etc. Noise may be generated in the
communication lines which might cause communication glitches.

Date issued	Oct. 21 ,2022	Panasonic Electric Works Networks Co.,Ltd.
Date revised		

Model Name	ZEQUO 4600RE	Product Specification	401-36241L-NZ-SP01
Model No.	PN36241L-NZ		Page 13 of 13

14. Basic Instructions for the Use of This Product

- (1) For inspection and/or repair, consult the shop.
- (2) Use commercial power supply from a wall socket, which is close and easily accessible to this Ethernet Switch.
- (3) Unplug the power cord when installing or moving this Ethernet Switch.
- (4) Unplug the power cord when cleaning this Ethernet Switch.
- (5) Use this Ethernet Switch within the specifications. Deviation could lead to malfunction.
- (6) Do not touch the metal terminal of the RJ45 connector, the modular plug of connected twisted pair cable, or the metal terminal of the SFP extension slot. Do not place charged objects in the proximity of them. Static electricity could lead to equipment failure.
- (7) Do not put the modular plug of the connected twisted pair cable on objects that can carry static charge, such as carpet. Do not place it in the proximity. Static electricity could lead to equipment failure.
- (8) Do not put a strong shock, including dropping, to this Ethernet Switch. Deviation could lead to equipment failure.
- (9) Before connecting a console cable to the console port, discharge static electricity, for example by touching metal appliance (do not discharge by touching this Ethernet Switch).
- (10) Do not store and/or use this Ethernet Switch in the environment with the characteristics listed below. (Store and/or use this Ethernet Switch in the environment in accordance with the specification.)
 - High humidity. Possible spilled liquid (water).
 - Dusty. Possible static charge (such as carpet).
 - Under direct sunlight.
 - Possible condensation. High/low temperature exceeding the specifications environment.
 - Strong vibration and/or strong shock.
- (11) Please use this Ethernet Switch in place where ambient temperature is from 0 to 45° C. Failure to meet the above conditions may result in fire, electric shock, breakdown, and/or malfunction. Please take notice because such cases are out of guarantee. Additionally, do not cover the bent hole of this Ethernet Switch. Deviation could lead to high internal temperature, equipment failure and/or malfunction.
- (12) When stacking Ethernet Switches, leave a minimum of 20 mm space between them.
- (13) When connecting the stacks, be sure to use firmware versions that are identical for all of the devices. Please note that operations are not guaranteed if the firmware versions are different.
- (14) Select the appropriate cables and lay them. Communications might be affected by how the cables are laid, and environmental noise.

Date issued	Oct. 21 ,2022	Panasonic Electric Works Networks Co.,Ltd.
Date revised		